



Agriculture and Natural Resources
Part of Cooperative Extension, UW-Extension
www.uwex.edu/ces/ag

NOTE to editor: This is one in a series of articles produced by University of Wisconsin-Extension agents and specialists to address farming in difficult times. More articles can be found on the Extension Responds website at:
www.uwex.edu/ces/ag/farmingindifficulttimes.html

May 2009

Contact: Scott Sanford, 608-262-5062, sasanford@wisc.edu

Managing in Difficult Times – Summer Forage Harvesting - Energy Savings Tune Up

Madison, Wis. – As you prepare for the hay and forage harvesting season, there are many simple activities that you can do to reduce production costs according to Scott Sanford, University of Wisconsin-Extension senior outreach specialist.

Mowing Hay

Sharp knives will reduce the energy to cut forage. On sickle bar cutting, the knife sections should set flat against the cutting surface of the guard. Worn pads on the guards (Figure 1) cause the knife section to ride above the guard and not cut properly. Hold down clips keep the knife against the guards and may need to be adjusted or replaced as they wear. They should be adjusted to a 0.010 inch gap. The maximum gap between the knife sections and the guard ledger area should be 0.030 inch for course crops and 0.020 inch for grass and seeding year alfalfa. The knife section can wear in three areas: along the back edge (A – Figure 2), at the cutting edge (B), and at the top of knife section (C). Replace sections where wear on the back edge or the cutting edge exceeds 3/16 inch or when grooves are cut into the top of the knife section. Replace dull knife sections so they don't slow the cutting process and cause uneven feeding of the crop.

Figure 1 – Sickle bar guard

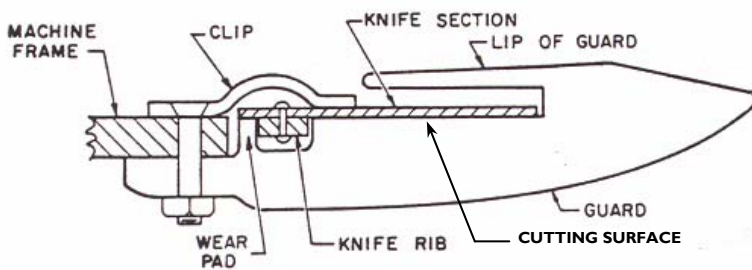
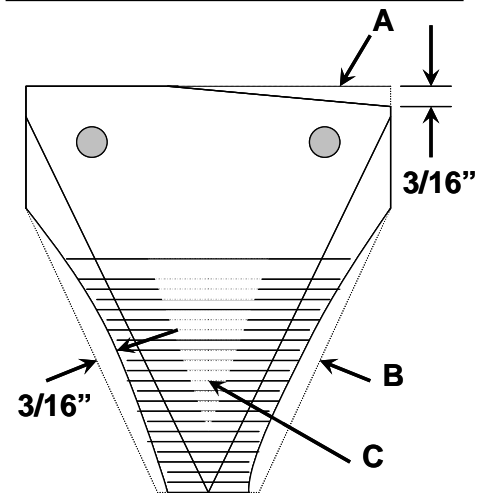

Figure 2 – Sickle knife Section



Rotary or disc mower knives are typically subjected to higher rates of wear and prone to more breakage because of their exposure compared to sickle bar mowers. Dull knives increase power requirements. Check knives and knife bolts each day before mowing and immediately after striking an object. Replace broken, worn or distorted knives, bolts and nuts.

Check your mower-conditioner or windrower owners manual for the proper roll clearance for the type of rolls your machine uses. The correct clearance will enhance conditioning by cracking the plant stem and promote faster drying. A piece of aluminum foil rolled up in a tube shape can be used to measure the gap according to Kevin Shinnors, UW-Madison professor of biological systems engineering. Place a foil roll in the middle and a foot from each end of the roller. Spin the roller by hand until the foil is completely through the rollers. Use a pair of calipers to measure the smallest thickness of the foil.

Laying the crop in a wide swath promotes faster drying and can reduce drying times by up to six hours under typical Wisconsin weather conditions compared to narrow swaths or windrows according to Ron Schuler, UW-Madison professor emeritus of biological systems engineering.

Raking

Many advances have been made with merging or inverting equipment for hay crop forage. Rakes and mergers can be used to promote drying by turning windrows and exposing new surfaces to air movement and sunlight. Merging windrows saves fuel by better matching harvester or baler capacity with crop yield. Harvesters and balers work more efficiently, and take less fuel per ton of crop if they are operated close to capacity. If the harvester is picking up a single swath and not loaded near machine capacity it will not only take longer but also wastes fuel.

Very often larger tractors than necessary are used for raking or merging. The power requirement for parallel bar or wheel rakes range from 20 to 40 hp; rotary rakes can range from 20 to 55 hp; and mergers require 50 to 70 hp. Based on the Nebraska Tractor Test data, a 45 hp utility tractor consumes 1.7 gallons per hour while a 100 hp row-crop tractor consumes 3.0 gallons per hour to pull a rake requiring 20 horsepower. Based on \$2.25 per gallon diesel

fuel, it would cost about \$3 per hour in increased fuel cost to use the larger tractor to do a light duty task.

Forage Harvesting

Three items have a significant effect on forage harvesting fuel consumption: length-of-cut, knife sharpness and knife-shearbar clearance. The cutting energy will double as the blade edge wears from a 0.004 inch radius (sharp) to a 0.012 inch radius (dull). The cutterhead power requirement also increases as the knife to shearbar clearance increases. The cutterhead power requirement will double for each 0.01 inch increase in clearance. The clearance can be caused by worn knives and worn shearbar or by knife sharpening. Each time the knives are sharpened, the shearbar must be adjusted. Refer to your forage harvester's operators manual for adjustment instructions.

Increasing the length-of-cut reduces fuel consumption but must be weighed against the nutritional requirements of the animals and storage facility. If you have a choice, longer length cuts will save energy and money. Roughly 40 percent of the energy used by a harvester is consumed by the cutterhead, so the effect on fuel consumption can be considerable from dull knives and worn shearbars.

All current forage harvesters can be equipped with processors to crush and crack kernels and cob for whole plant corn silage. Based on research, there isn't any benefit to using a processor on hay forage crops, therefore it is recommended that the processor be removed from the crop stream when harvesting any other crop.

Balers

Lubricating and making adjustments according to the manufacturer's recommendations will reduce down time and maintenance issues. Balers like forage harvesters are most efficient if operated near capacity so combining windrows to maximize baler capacity will reduce the time and energy required. Square Balers – Sharpen and adjust the clearance of the plunger and stationary knives on the feeder side of the bale chamber. Dull knives increase power consumption.

Blowers

Blowers are generally the bottleneck or the machine that limits the capacity of forage harvesting when using tower silos. There are several things that will reduce the energy consumption and maximize the capacity of the blower.

A blower is essentially a throwing device. Once material enters the blower it is quickly directed to the outer wall of the blower housing and accelerated to approximately the tip speed of the fan. Once the material leaves the fan tip, it can be slowed down by gravity, air drag and friction from contact with the blower pipe. Therefore it is important the pipes are straight and in-line with the blower discharge. Any dents, kinks, or elbows cause materials to contact the pipe and reduce its velocity.

The clearance between the fan tip and the housing is the most important adjustment on a forage blower. The rule of thumb is that the blades will move a nickel but pass over a dime – about 1/16 inch clearance. The most critical zone is from the bottom of the housing to the horizontal point of discharge. Blade tip wear increases the clearance so checking the clearance each time the blower is moved to a new silo is a good practice.

No matter what hay or forage harvesting operation you are conducting, the most important energy savings task you can perform is to carefully and properly maintain your equipment and tractors. Simple tasks like cleaning radiators, keeping air filters clean, properly inflating tires, sharpening knives and checking clearances can each save fuel in small ways, adding up to a more profitable cost per ton of feed. When making many of the adjustments discussed above, make sure to use safe practices including eye protection when sharpening knives and cylinder stops in place when adjusting roll clearance.

To access more information and/or tools to help analyze your situation, link to the Extension Responds web page at: www.uwex.edu/ces/ag/farmingindifficulttimes.html

For assistance in making these tough decisions, contact your UW-Extension county agent, your Farm Business and Production Management Instructor in the Technical College or the DATCP Farm Center at 1-800-942-2474.

###

File: farming in difficult times