



## Expansion Feeding

H 73

John T. Tyson, Agricultural Engineer, Erie County  
 Robert E. Graves, Professor of Agricultural Engineering

As cow numbers and production increase so does the need for increased quantity, quality, and variety of feed stuffs. Also, the methods for storing and handling feed may change. Many animals previously housed in tie stalls and fed by hand are now in freestalls and fed with a mobile TMR mixer. This new system must be capable of handling large quantities of feed very quickly and very efficiently, both into and out of storage. More materials will be handled in bulk to save money and improve efficiency. This new system will also consume a large area. Often the area of the feed center equals that taken up by the freestalls and parlor.

A dairy operation can grow into a well-planned feed center. The whole center must be laid out to match the final goal of where the dairy is heading. As cow numbers are increased, the feed center can be expanded as planned.

The goal at the end of expansion is to allow one person to conveniently feed the various groups of animals no matter where they are located on the farmstead. At times during expansion, feed storage may be spread out and feeding may be less efficient, but remember that the extra time spent during one or two years of expansion is part of the cost of an efficient system which will be used for the life of the new dairy.

### Incremental Expansion

Incremental expansion is a process where individual pieces, or building blocks, are constructed as the farm grows. However, each piece is preplanned and contributes towards the final goal of a modern, efficient dairy. Building a lean-to onto the side of a barn is not incremental expansion; that is a patch job!

Lay out the total system and then construct the pieces as they are needed. Complete system

(operational) planning is the best approach. System planning needs to consider cow housing, feed storage and delivery, parlor location, manure removal, possible manure storage, machine storage, and future expansion. Consider travel routes for vehicles bringing in or taking away feed. Provide for flexibility, farmsteads aren't and probably never will be static.

The most important part of expansion is planning. How are we to get where we want if we don't know where that is? Incremental expansion can be thought of as a jigsaw puzzle. However, remember that a puzzle was a whole picture first, and then someone cut it up to make a puzzle. Therefore, if the picture wasn't right to begin with or a piece is missing, the puzzle will never fit together.

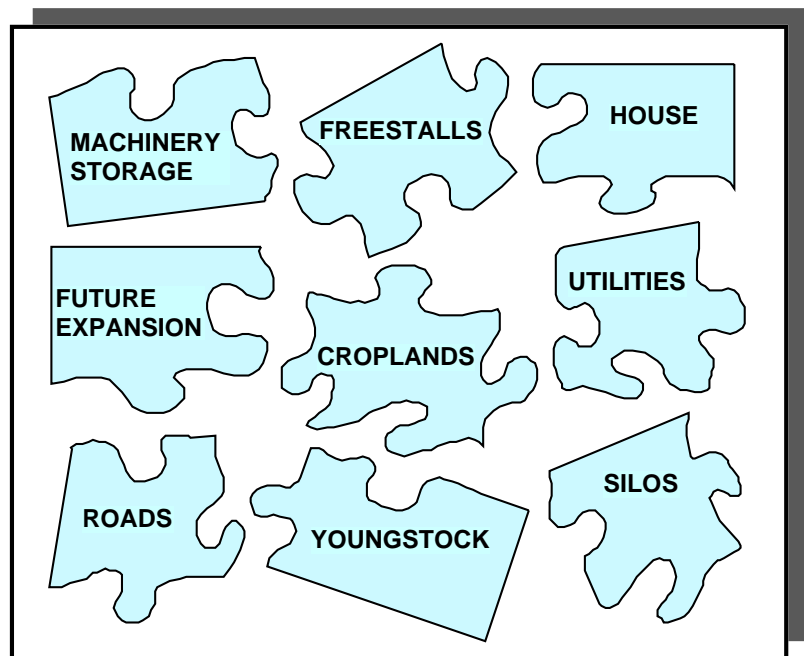

There needs to be a logical sequence to building a feed center. Forages are the largest part of a ration, the hardest to buy, and need good management to get good quality. Therefore, storage for forage is the first

logical choice. While commodity feeding can save money, it requires management time, which is at a premium during early expansion. Therefore, commodity storage is secondary to forage storage

other than for a purchased pre-mix grain. High moisture grains store well in most existing tower silos. Therefore, a new facility for this is usually the last part of the system.

.....

## Five Step Plan for Incremental Expansion of Feed Storage and Handling

### Existing Farmstead

- 50 cow tie stall barn with pipeline milker
- three tower silos for corn silage, hay crop silage and high moisture corn
- metal bin for grain mix

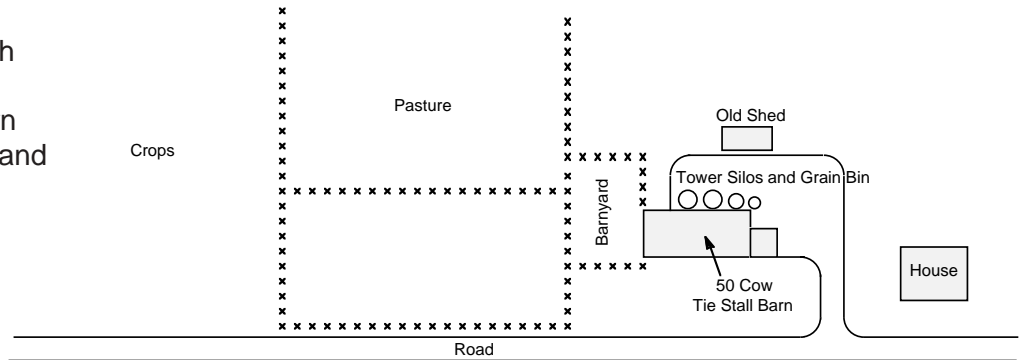

### Goal

- drivethrough freestall barns for 500 cows
- milking center with cow treatment area
- feeding with mobile TMR mixer
- horizontal silos for corn silage, hay crop silage and high moisture corn
- eight bin bulk storage building with attached shed for micro ingredients

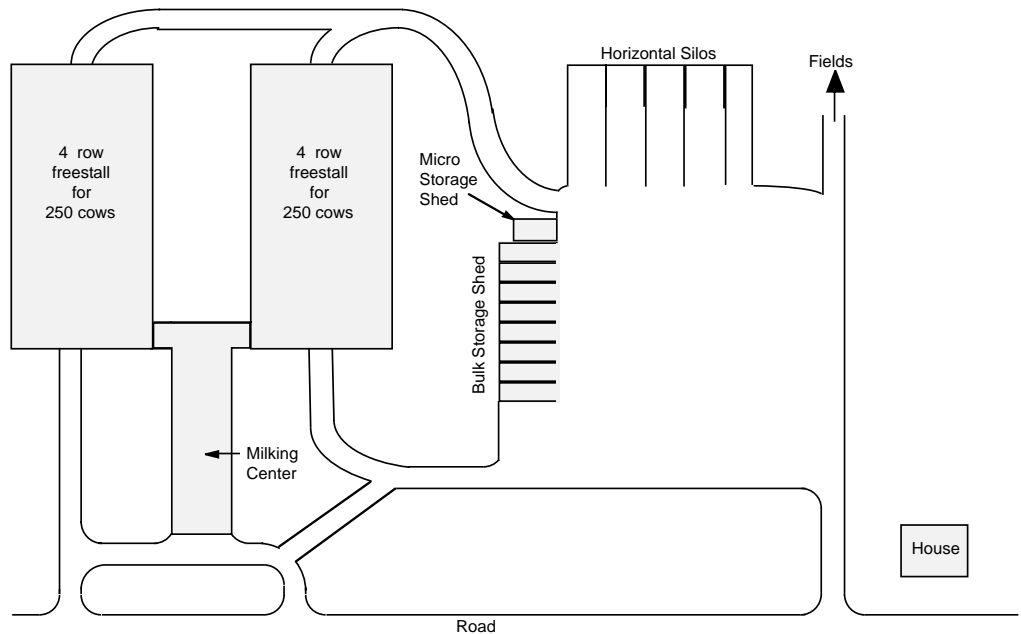

### Step 1

- drivethrough freestall barn for 100 cows
- mixer wagon feeding
- milking in existing tie stall barn
- two horizontal silos for hay crop silage
- corn silage and high moisture corn stored in existing tower silos
- grain mix stored in metal grain bin
- micro ingredients stored in hay mow and silo room

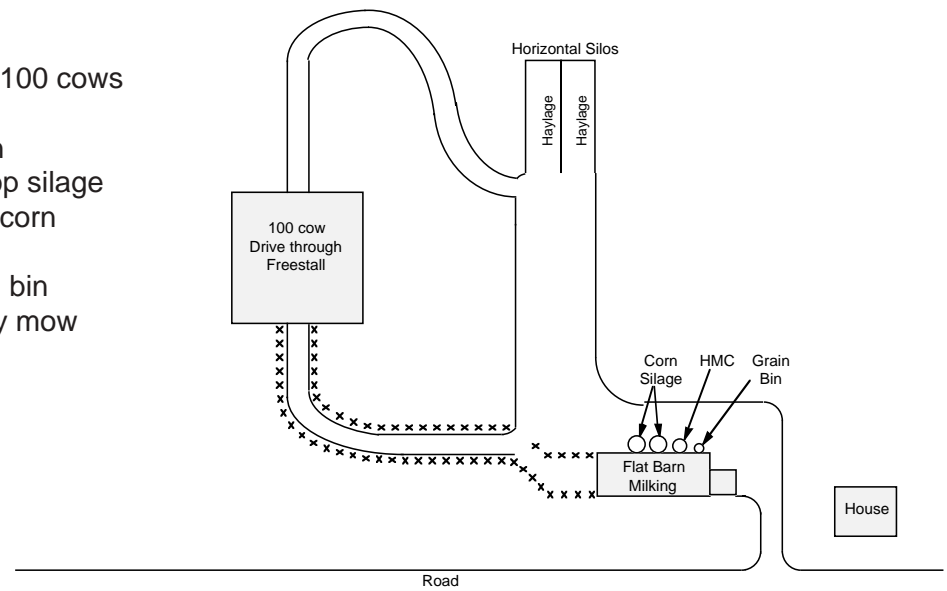

### Step 2

- a two bay bulk storage shed is built
- a used truck van is used for micro ingredient storage
- metal grain bin removed

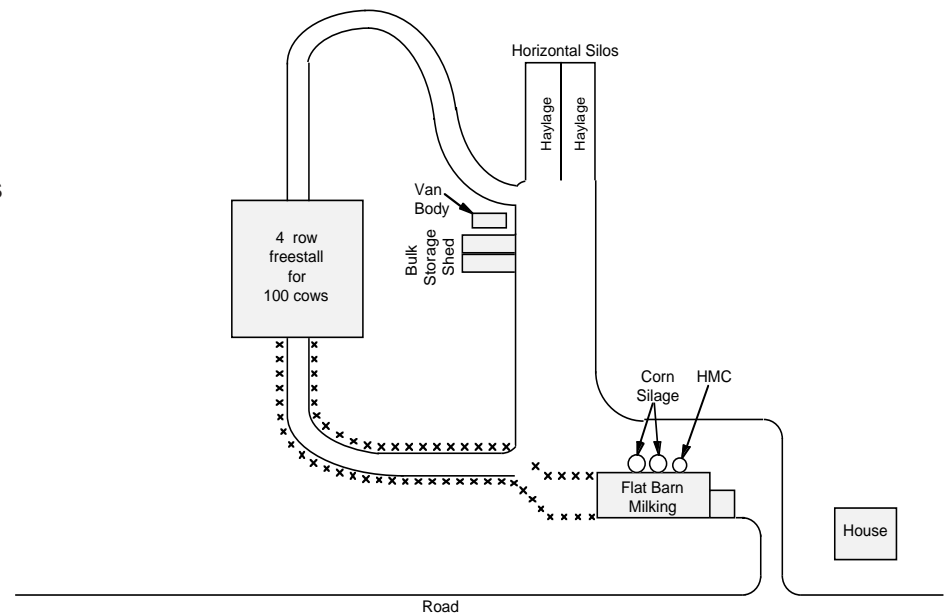

### Step 3

- freestall barn expanded for 250 cows
- "bare bones" milking parlor built
- tie stall barn converted for maternity and youngstock
- additional horizontal silo and area for silage bags
- one tower silo is used for corn silage to be fed during harvest
- high moisture corn stored in two tower silos
- 2 bays added to bulk storage building

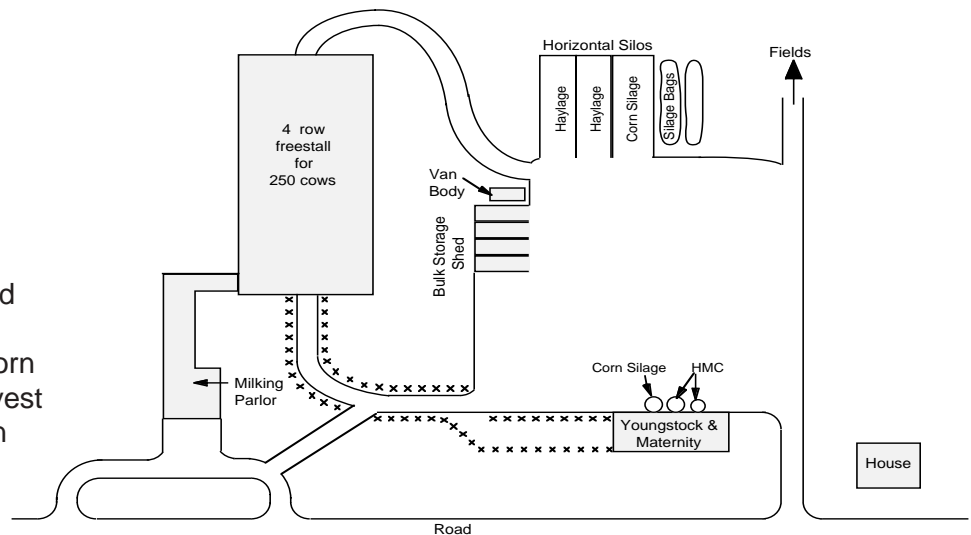

### Step 4

- fourth horizontal silo added for corn silage
- oldest tower silo demolished
- two bays added to bulk storage shed

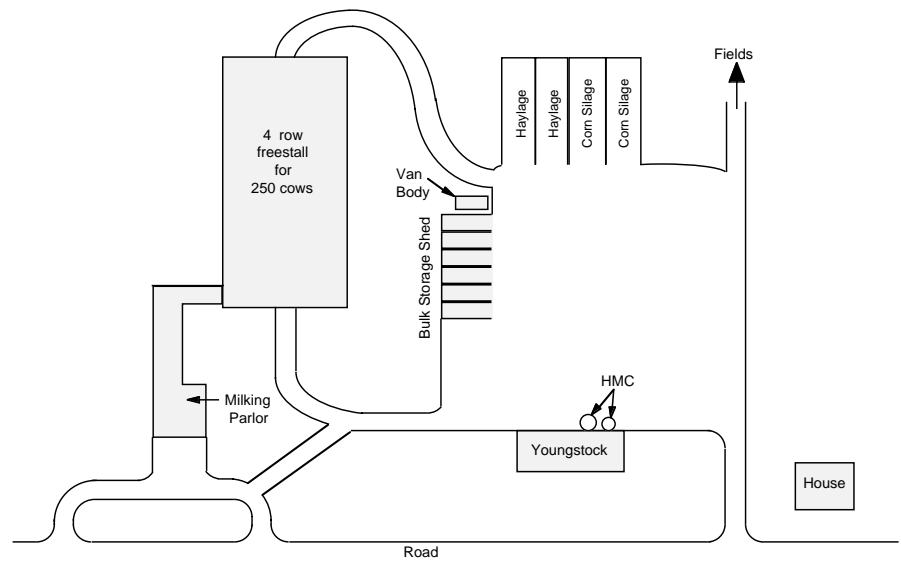

### Step 5

- second freestall barn added for 250 more cows
- milking parlor upgraded and building expanded to complete milking center and treatment area
- youngstock barn built
- horizontal silo expanded to accommodate high moisture corn
- tie stall barn and remaining silos demolished
- two bays and a micro ingredient storage area added to bulk storage building

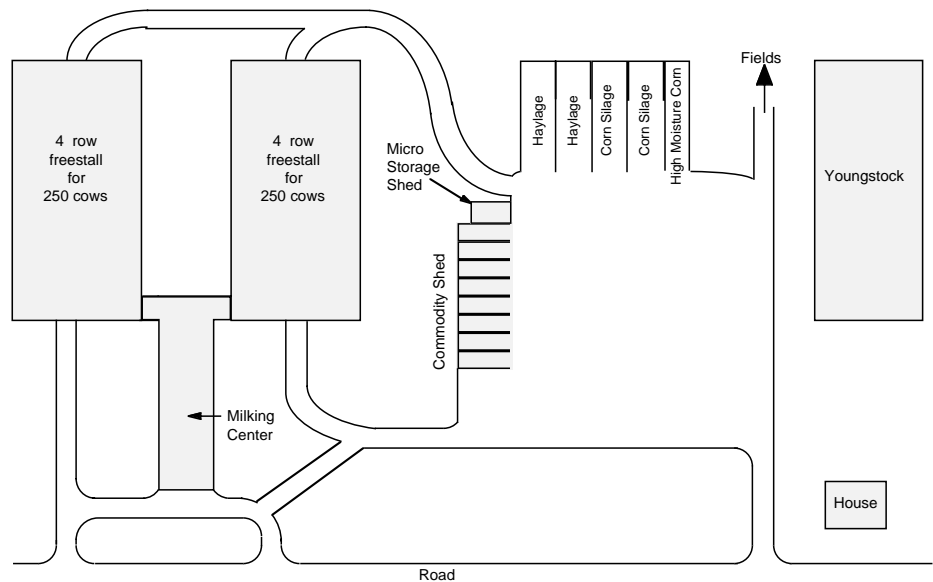

### Room Saved for Future Needs

- additional milking cow and youngstock housing
- dry cow maternity
- enlarge feed storage
- storage for feeding equipment
- house converted to farm office

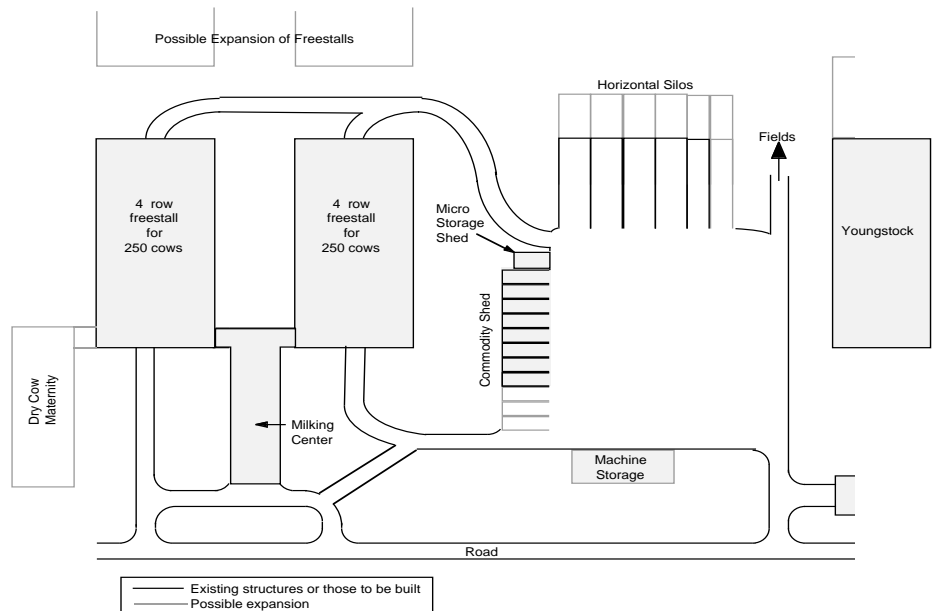

## Using Tower and Horizontal Silos Together

---

Often during expansion, feed is stored in both existing tower silos and new horizontal silos. Tower silos can be used for high moisture grains, corn silage, or hay crop silage. The feed that is actually stored may be dictated by the desired ratio of hay crop to corn silage, the tower silo's capacity and unloading system, and the harvesting capacity of machinery. This will vary depending on the individual operation. Take some time to lay out the actual harvest, storage, and feeding schedule and see how existing tower silos can best fit into the future operation. One option for an existing tower silo is to hold enough silage to allow proper filling and fermenting of a large horizontal silo that holds the majority of the farm's silage needs.

The method used to move feed from the tower silo into a mixer is often a bottleneck with a mobile system. A loader tractor can scoop up silage out of a bunk and dump it into a mixer much quicker than a mechanical unloader can empty a tower silo. It is tempting to go do something else while a silo unloader discharges directly into the wagon or onto a pile for later pick-up with the tractor loader. However, problems during your absence may include the following:

1. unloading the proper amount.
2. the need to lower top unloaders as they remove silage.
3. proper cleaning of the silo walls.
4. possible equipment damage from unattended operating unloaders and conveyors.
5. safety concern of allowing unloader to operate unattended.

A variety of methods including timers, interconnection of unloader controls with wagon scales, alarm bells and lights, and safety switches can be included to minimize these problems. Even with control devices, tower silo unloaders must be periodically monitored and adjusted. The cost and inconvenience of using tower silos with mixer wagon feeding must be weighed against the opportunity to use existing storage structures. The use of existing tower silos must be compared to long-term goals of an expanding dairy.

Do not let existing tower silos prevent you from planning for an efficient feeding system in the future. These units will decrease in value as needs for efficient, flexible, and economical feed storage increase.

Existing tower silos may also be converted for alternative uses. Dry, shelled corn can be stored in a silo constructed to store corn silage or hay crop silage but may require modification to ensure structural integrity. An aeration system must be added to ensure satisfactory long-term storage. Tower silos can also be rebuilt for continued use by overhauling the total silo. Converting bottom unloaders to top unloaders may be more

economical than rebuilding floors and replacing bottom unloaders. However, the cost of rebuilding the silo must be compared to the value of the structure in the overall feeding system. Will this structure continue to be used in the future or is this simply a patch job for the next year or two? If this is simply a patch job, maybe the money would be better spent on the first step to building a new silo, such as grading a site and bringing in gravel for a future horizontal silo.

## Temporary Silage Storage

---

During the course of expansion, temporary storage for silage may be necessary. This storage is needed because new storage could not be constructed in time or the capital for such an investment was not available. However, temporary storage is often inconvenient to fill and/or empty and may result in higher dry matter losses.

There are four basic types of temporary storage: stacks, movable or portable bunker systems, trenches, and horizontal plastic bags.

Stacks are little more than a compacted pile of high moisture material. Effective packing of a pile is difficult, resulting in high dry matter losses. With side slopes shallow enough to allow effective packing, the surface area exposed is very large.

Temporary bunker systems that have been used successfully include wooden A-frame sidewalls, sidewalls made from fence posts and rough cut lumber, sidewalls formed with large round bales, and the area between silo bags. The wooden A-frames are both movable and reusable, while the round bales and silo bags are a one-time use. Whatever the material used to construct the sidewalls, they need to be anchored either to each other or the ground.

Trench silos are usually dug into a hill or bank with their long dimension either perpendicular or parallel to the hill. Removed soil can be used to increase sidewall height or extend the length of the trench.

A horizontal bag system is readily adaptable to either temporary or normal use. Annual costs of silo bags on a \$/yr/cow basis are slightly higher to that of a horizontal silo. A 1986 study showed a \$3 to \$12 difference on herds from 90 to 300 cows. Another bag system that has gained popularity is baleage. Systems vary from individually-wrapped bales to several bales in a single bag. However, in most feeding systems, the bales must be processed to be used in the TMR mixer. Care must be taken to protect the plastic from cuts and tears on an unprepared site. Place the bags on a well-drained site, preferably oriented north/south to promote snow melt and side drying.

Plastic disposal must also be addressed. A portion of the plastic can perhaps be used for tarp-like material or for winter animal shelters. However, if large amounts are used, the issue of disposal or recycling must be addressed. Two fact sheets concerning recycling agricultural plastics are listed at the end of this fact sheet.

Site selection and preparation are important for convenience and to ensure good quality feed from temporary storage. Consider access routes for filling and unloading, an all weather working surface, and site drainage. When possible, locate temporary storage where future permanent storage will be constructed. Site preparation costs to make temporary storage more effective will also be an investment in future permanent storage. Good roads and a well-graded and compacted gravel surface can accommodate silage bags or piles now and a bunker silo with walls and hard surfaced floor later.

Locate temporary storage on an elevated site with a 3 to 5 percent slope that will allow rain and snow to drain away. Also consider snow drift patterns. Don't locate a storage where snow might restrict access. Locate away from wells to minimize contamination danger due to seepage, and leave maneuvering space for equipment. Keep away from woods, trash piles, and other possible shelters of rodents, squirrels, and other animals that will gnaw holes in the cover, looking for food and shelter. Keep weeds down to reduce wild animal damage, and inspect frequently and repair any holes or cuts in the cover.

## **Bulk Storage**

Commodity feeding can save money on feed costs for large or small herds, but requires more management than simply buying a commercial pre-mix. It usually isn't one of the early steps because of the investment in the building and management required but should be considered as part of the whole plan. As the expansion moves on and the management demands level out, then is the time to take on this extra

responsibility. For smaller herds, traditional metal or plastic grain bins make good alternatives for bulk storage. Locate these to provide convenient access for the mixer wagon. Determine the actual amount of commodity needed and spoilage that might occur in storage before selecting the type of storage.

Perhaps the more important question during expansion is the storage of medium volume or micro items. Use of items like minerals, salts, and calf grain may not be large enough for bulk storage, but the number of bags or sacks that need to be stored will no longer fit between the tower silos on a pile like they did before. A common solution for these things is to use one bay of a commodity shed, which tends to be a waste. Another option is a small, gravel-floor shed with items on pallets. This can be a small addition to a commodity shed, or it could be the first step to the commodity shed. But don't build it onto the back of the barn where it will serve no purpose in the future when the whole system is built. Another solution is the use of a van body for storage. Most often they are cheap and can be moved when their purpose changes.

Related Fact Sheets Available From Agricultural and Biological Engineering

C-8 Recycling Used Agricultural Plastics

C-22 Recycling Your Used Agricultural Plastics

H-70 Silo Capacities

H-72 Site Evaluation for Dairy Housing Systems

H-74 Feed Center and Components

H-75 Bulk Storage

H-76 Horizontal Silos

Extension Circular 396 Harvesting & Utilizing Silage

Related "for sale" publications contact: Publications

Distribution, 112 Agricultural Admin., University Park, PA

16802 (814) 865-6713. Call for current prices and availability.

MWPS-7 Dairy Freestall Housing and Equipment

MWPS-13 Grain Drying, Handling, & Storage Handbook

NRAES-38 Dairy Feeding Systems Proceedings

NRAES-77 Expansion Strategies for Dairy Farms

PSU 8/96

**The Pennsylvania State University is committed to the policy that all persons shall have equal access to programs, facilities, admission, and employment without regard to personal characteristics not related to ability, performance, or qualifications as determined by University policy or by state or federal authorities. It is the policy of the University to maintain an academic and work environment free of discrimination, including harassment. The Pennsylvania State University prohibits discrimination and harassment against any person because of age, ancestry color, disability or handicap, national origin, race, religious creed, sex, sexual orientation, or veteran status. Discrimination or harassment against faculty, staff, or students will not be tolerated at The Pennsylvania State University. Direct all inquiries regarding the nondiscrimination policy to the Affirmative Action Director, The Pennsylvania State University, 201 Willard Building, University Park, PA 16802-2801, Tel 814-865-4700/V, 814-863-1150/TTY.**