

University of Wisconsin – Madison, College of Agricultural and Life Sciences (Dr. Roger Wyse, Dean)
Department of Biological Systems Engineering (Dr. J. Converse, Chair)
Milking Research and Instruction Laboratory (Dr. G. A. Mein and Dr. D. J. Reinemann, Directors)

Technical design and assessment of tube equipment using two-phase flow for cleaning and disinfection*

Technische Auslegung und Beurteilung von Rohrleitungssystemen unter Einsatz von Zweiphasenströmung zur Reinigung und Desinfektion

DOUGLAS J. REINEMANN

With 2 figures

Abstract

Most pipeline systems in dairy and food processing plants are cleaned by circulating cleaning solutions under pressure with a liquid pump. The flow of the circulated solutions is single-phase or flooded flow. Milking system pipelines are subject to special requirements which distinguish them from those in dairy and other food processing plants. Milking system pipelines are considerably larger in diameter than product lines in dairy plants because they must carry both milk and air in a stratified flow condition during the milking process. Milking machine Clean-In-Place (CIP) systems have historically used flooded flow to circulate cleaning solutions. The force to move liquid, however, is typically the vacuum provided by the same vacuum pump used during milking, rather than a positive pressure liquid pump.

As the size and complexity of milking machines has increased in recent years, flooded flow CIP systems have become inadequate. The amount of water required to fully flood a milking system becomes impractical with very long and/or large diameter pipelines. The power available to achieve adequate flow velocity is also limited. Air admission has been used to produce two-phase (air/water) slug flow and overcome some of the limitations of fully flooded CIP. Cycled air admission can reduce the amount of water required for circulation and increase flow velocities and thus enhance mechanical cleaning action.

Cycled air admission has been implemented in the field largely through trial and error methods. There has been a lack of fundamental design information and testing protocols for air-injected milking machine CIP systems. This has resulted in mixed success in the application of air injected systems. This paper summarizes both laboratory and field research

* Vortrag aus Anlaß der 14. Düsseldorfer Hygienetage am 24. und 25. April 1996 (Veranstalter: Henkel KGaA, Düsseldorf).

conducted at the University of Wisconsin Milking Research and Instruction lab to provide basic information for the design of air injected CIP systems and methods for field assessment of these systems. Just as properly implemented air-injection can improve cleaning and sanitation in milking machines with less water and energy, so to it may have applications in the cleaning of other types of tube equipment.

Zusammenfassung

Die meisten produktführenden Rohrleitungen in milch- und lebensmittelverarbeitenden Unternehmen werden dadurch gereinigt, daß eine Reinigungslösung unter Druck mit einer Pumpe durch die Leitungen zirkuliert wird. Die Strömung der zirkulierten Lösung ist einphasig oder eine Totalflutung. Milchsammelleitungssysteme unterliegen besonderen Anforderungen, die sie von denen in milch- und lebensmittelverarbeitenden Unternehmen unterscheiden.

Milchsammelleitungssysteme haben einen erheblich größeren Durchmesser als produktführende Rohrleitungen in milchverarbeitenden Unternehmen, da sie sowohl Milch als auch Luft in einem stratifizierten Strömungsverhältnis während des Melkvorganges führen müssen. Melkmaschinen, die gereinigt werden, ohne die Maschine auseinanderzunehmen (im Englischen Clean-in-Place (CIP), haben in der Vergangenheit die Reinigungslösung mit Totalflutung zirkuliert. Die Kraft, die die Flüssigkeit bewegt, ist jedoch typischerweise das Vakuum, das durch die gleiche Vakuumpumpe erzeugt wird, die während des Melkvorganges benutzt wird, und nicht eine Überdruckpumpe. Dadurch, daß Melkmaschinen in den letzten Jahren in Größe und Komplexität zugenommen haben, sind Totalflutungs-CIP Systeme nicht mehr ausreichend. Die Wassermenge, die benötigt wird, und das Milchsammelleitungssystem vollständig zu überfluten wird unpraktisch, wenn Leitungssysteme sehr lang werden oder einen breiten Durchmesser haben. Die Leistung, die gebraucht wird, um eine ausreichende Fließgeschwindigkeit zu erreichen, ist auch begrenzt. Luftzutritt wurde benutzt, um zwei-phasige (Luft/Wasser) „Pfropfen-Strömung“ (im Englischen slug flow) zu erzeugen und die Begrenzungen eines Totalflutungs-CIP zu überwinden. Intervallluftzufuhr kann die benötigte Wassermenge reduzieren, die für den Kreislauf und die erhöhte Fließgeschwindigkeit erforderlich ist und somit die mechanische Reinigungstätigkeit verbessern.

Intervallluftzufuhr wurde in der Praxis primär durch Ausprobieren eingeführt. In diesem Bereich gibt es jedoch einen Mangel an grundlegenden Designinformationen und Versuchsrichtlinien für luftzuführende CIP Melkmaschinen. Das hat zu einem gemischten Erfolg in der Anwendung von luftzuführenden Systemen geführt. Dieser Beitrag faßt sowohl Labors als auch Feldversuche zusammen, die an dem Milking Research and Instruction Labor der University of Wisconsin durchgeführt wurden. Die Forschungsarbeiten wurden durchgeführt, um grundlegende Informationen für das Design von luftzuführenden CIP Systemen und Methoden für die Bewertung von Feldversuchen dieser Systeme zur Verfügung zu stellen. So wie eine richtig verwandte Luftzufuhr die Reinigung und Hygiene von Melkmaschinen mit weniger Wasser und Energie verbessern kann, so kann sie auch Anwendung für die Reinigung anderer Arten von Rohrleitungssystemen finden.

Introduction

Most pipeline systems in dairy and food processing plants are cleaned by circulating cleaning solutions under pressure with a liquid pump. The flow pattern of the circulated solutions is single-phase or flooded flow. Milking system pipelines are subject to special requirements which distinguish them from those in dairy and other food processing plants. Milking system pipelines are considerably larger in diameter than pro-

duct lines in dairy plants because they must carry both milk and air in a stratified flow condition during the milking process. Milking machine Clean-In-Place (CIP) systems have historically used flooded flow to circulate cleaning solutions. The force to move liquid, however, is typically the vacuum provided by the same vacuum pump used during milking, rather than a positive pressure liquid pump. As the size and complexity of milking machines has increased in recent years, flooded flow CIP systems have become inadequate. The amount of water required to fully flood a milking system becomes impractical with very long and/or large diameter pipelines. The power available to achieve adequate flow velocity is also limited with the equipment available as part of the milking machine.

As the milking system is under partial vacuum during the cleaning process, it is possible to draw a large volume of air into the system. Air admission has been used to produce two-phase (air/water) slug flow and overcome some of the limitations of fully flooded CIP. Cycled air admission can reduce the amount of water required for circulation and increase flow velocities and thus enhance mechanical cleaning action. The objective in air injected flow is to form a 'slug' of cleaning solution and move this slug around the entire pipeline. The slugs may vary from a few centimeters up to several meters in length. The area between the slugs contains a slower moving liquid film in the bottom of the pipe.

Cleaning and disinfection are accomplished by a combination of chemical, thermal and mechanical actions. The mechanical action is provided by the shear stress developed at the pipe wall. The design flow velocity for flooded CIP systems are typically about 3 m/s. The slug velocities developed with air injected two-phase flow can be 3 to 5 times higher, and the wall shear stress developed ten to twenty times higher than those in flooded CIP circuits. The contact time between the slug and pipe wall is significantly reduced, however.

Two-phase, air-water flows have been widely studied and described in comprehensive reviews (2, 3, 13). Air-injected CIP flow differs from that encountered in most two phase flow literature in several respects. First, the flow is unsteady. Liquid enters the milking line periodically at a low velocity and a slug is formed by periodic air admission. This slug is rapidly accelerated and changes length as it travels. The milking line is partially filled by a liquid layer ahead of and behind the slug which moves in the same direction as the slug but at a lower velocity. Second, there is usually only 1 slug in the milking line at any time. This differs from fully developed slug flow in which there are a series of slugs moving through the line. Third, the system is under partial vacuum rather than under pressure. One study of air injected milking line cleaning dynamics has been previously reported (12). The study was done in a 34 mm diameter pipe and used steady air admission rather than the cycled air admission.

Cycled air admission has been implemented in the field largely through trial and error methods. There has been a lack of fundamental design information and testing protocols for air-injected milking machine CIP systems. This has resulted in mixed success in the application of air injected systems.

This paper summarizes both laboratory and field research conducted at the University of Wisconsin Milking Research and Instruction lab to provide basic information for the development of standardized soils typical of those found in milking system, test methods to assess removal of this soil, design of air-injected CIP systems and methods for field assessment. Just as properly implemented air-injection can improve cleaning and sanitation in milking machines with less water and energy, so it may also have applications in the cleaning of other types of tube equipment.

Fundamental Concepts of Milking Machine CIP System Design and Operation: Although system designs vary considerably, typical features of milking parlor CIP systems are shown in Figure 1. Cleaning solutions are transported from the wash vat through the sanitary parts of the system and back to the wash vat during the CIP process. These solutions must make contact with all milk contact surfaces for sufficient time, and with sufficient physical action, to assure cleaning. Two-phase flow patterns are determined by the diameter of system components and water and air flowrates. Internal diameters range from 10 mm in short milk tubes to 98 mm or more in milklines and in excess of 150 mm in milk meters and recorder jars. Flow velocities and flow patterns therefore vary greatly in the different parts of the system. Air-injection is normally used to produce slug flow in milklines. The objectives and optimal control strategies for air and water admission to milking units and other components differ from those for the pipeline. Milking units are either flooded or alternately flooded and emptied. Large components such as some milk meters and recorder jars are generally cleaned with a spray or sheet of water over the interior surfaces.

In milking parlors, milking units are commonly attached to wash assemblies (jettors) fed from a wash line. This water-draw pipe network and jettors make up the wash manifold. Cycled air-injection may enter through the wash manifold (A1 in Figure 1), the milkline (A2 in Figure 1) or both. When air is injected only through the wash manifold (A1) it is common to include a hose or pipe from the water drawline directly to the milkline (the dashed line in Figure 1). Air and water are separated at the receiver jar. The air travels to the distribution tank and is removed from the system by the vacuum pump. Water is returned to the wash vat by the milk pump through the milk transfer line.

Milklines must be sloped between 1 and 2 percent toward the receiver jar to prevent slugging in milklines during milking. All pipelines, hoses and components must also be installed so that they will drain by gravity between cleaning cycles. Drainage is an im-

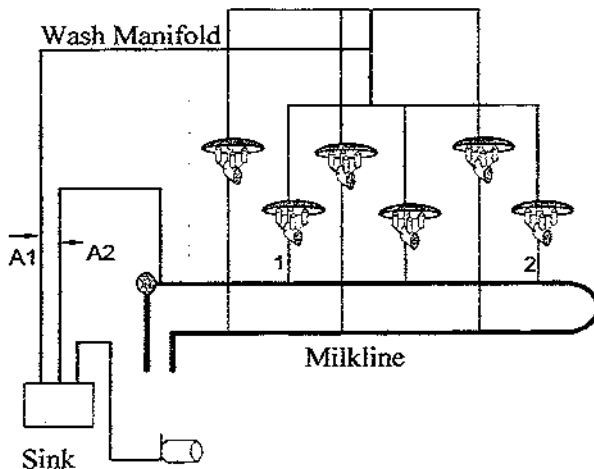

Fig. 1. Typical features of milking parlor CIP systems.

Abb. 1. Typische Merkmale eines CIP-Reinigungssystems für Melkmaschinen.

portant aspect of cleaning, because any standing water in the system increases the risk of bacterial growth between milkings and mixing of different cleaning chemicals during cleaning.

The use of cycled air injection through milking units has been referred to as controlled flushing pulsation by *Lind* (5). He noted that equal distribution of water to all units is a problem in large parlors. A recent study by *Wolters* (14) showed that increased system vacuum improved the removal of residual milk from milking units and milk meters in flooded systems during the prerinse process. The use of cycled air admission and controlled flushing pulsation also improved prerinse performance without using a higher vacuum level. No measurements of water or air flow rates were reported, however.

Australian standards (1) require that wash lines be sized to meet the manufacturer's specifications for the minimum water flow rate per jetter (although most manufacturers do not specify this value). This standard further states that water flow rate through any unit should not be less than 3 L/min, and the flow rate through the first unit should not exceed that through the last unit by more than 50 percent. This standard does not give guidelines for air injection methods or air flow rates.

Materials and Methods

A series of experiments were performed to characterize the different aspects of air injected flow in milking CIP systems. Several methods of developing milk soil deposits and assessing residual soil were also developed.

Slug flow in milklines: Experiments were performed to characterize the type of unsteady slug flow developed in milklines when cycled air admission is used (4, 7). The layout, dimensions, internal volume, and operating characteristics of the test system were representative of modern milking systems. Pipe diameters ranging in diameter from 48 to 98 mm were tested. The experimental system monitored air and water admission volume and rates, the liquid fill depth in the pipe, slug velocity, slug length, and vacuum level in the pipe.

Flow through milking components: Additional studies were performed to determine the flow characteristics of typical jetter/milking units combination for both flooded and air-injected flow and factors affecting the distribution of water flow between units for typical milking parlor CIP system designs. Control strategies were developed to balance wash water flow between milking units, optimize cleaning of both milking units and the milk pipeline and reduce the vacuum pump capacity needed for milking parlor CIP systems (6, 8, 9).

Bacterial attachment to pipe wall: Several methods were developed to apply bacteria, milk soil and combined bacteria and milk soil deposits (10, 11). Test sections were designed to allow placement of soiled chips into the pipe wall without disturbing the flow stream. Each test section was mounted horizontally on a shaft/rotor apparatus, filled with 100 mL of 1:1000 dilution of pasteurized whole milk inoculated with about 10^9 cfu/mL of a *Lactobacillus* culture. The test section was rotated at 10 rpm for two hours at room temperature to allow uniform deposition of milk soil and lactobacilli on the surface of the pipe. The milk was removed from the pipe section, which was then placed in the milking system and subjected to specified cleaning conditions. Test chips from one collar were removed prior to cleaning and processed for enumeration of initial lactobacilli counts.

A series of tests were run using plain water at room temperature to isolate the effects of physical action on bacterial removal. Wall shear stresses ranging from 50 to 250 N/m², were examined. A second series was run using plain water and several formulations of alkaline detergents at temperatures ranging from 43 °C to 70 °C and at two levels of shear.

Bacterial attachment to milking components: Tests were performed on an commercial milking unit and milk meter to examine the flow conditions encountered in objects with com-

plex flow geometry. The same *Lactobacillus* culture described above was used for all trials. The milking unit and milk meter were filled with the bacterial suspension and left stationary for 1 h at room temperature to allow bacteria to attach to the interior surfaces. After 1 h, the bacterial suspension was poured out of the milking components and the components rinsed with distilled water to remove non-adhering bacteria. The milk meter and milking unit were then installed in a milking system according to the manufacturers recommendations. Cleaning tests were performed with both plain water and a detergent solution. Standard plate count methods were compared with ATP-Bioluminescence assessment methods.

Multiple-layer milk soil and bacterial deposit: A spraying apparatus was constructed to deliver multiple thin layers of milk-soil to test chips. The chips were placed on a turn table that passed to chips under a spray head once per minute. Warm air was circulated in the deposit chamber so that each film would dry between spray cycles. The chips are sprayed for four hours to develop approximately 240 milk soil layers. Three types of milk-soil were used. The first type used a mixture of nine parts of pasteurized milk and one part of phosphate buffer solution with 9% albumin added to the mixture. Addition types were prepared by adding an *L. fermentum* ATCC 8289 suspension to the milk soil mixture. One of these inoculated mixtures was cleaned immediately and the other was allowed to incubate for 24 hours before cleaning. Milk soil and bacterial residuals on the test chips were measured using both a standard BCA Protein Assay Reagent (Pierce™ cat no 23225) and with the ATP bioluminescence method.

Results

Slug Flow in milklines: The desired condition for cleaning is to contact all milkline surfaces with the slug of liquid at adequate velocity to provide mechanical cleaning action. If the slug breaks before reaching the receiver, due to insufficient initial slug size, insufficient air injector open time or excessive air admission, portions of the milkline surface will not come into contact with cleaning solutions. When one slug is formed at the beginning of the milkline and maintained through the entire system, all surfaces will be in contact with the slug. In order to achieve this the air injector must be left open long enough for the slug formed at the air injector to travel the entire milkline. The initial slug length must be also sufficient and air injection rates limited so that the slug will not dissipate before it reaches the receiver. Excessive slug size causes flooding of the sanitary trap and is undesirable as this stops the cleaning process.

The ratio of air-to-liquid velocities, referred to as the slip ratio, is a parameter commonly used to describe two phase flows. The ratio of air to liquid velocity ranged between 1.1 and 2.2. Increased pressure difference across the slug, and reduced slug length increased the slip of air past the slug. The inverse of the slip coefficient can be used to estimate the slug void ratio (volume of air in the slug/total air and water volume in the slug). The slug void ratio ranged from 0.5 to 0.9 with most values between 0.7 and 0.8 (4, 7).

Slug velocities of 7 to 10 m/s maximize the wall shear stress developed while minimizing the variation of shear stress along the pipe. The rate of air admission to the milkline should be controlled to achieve these slug velocities. Air admission rates above this maximum will result in reduced slug density and reduced mechanical cleaning action in the milkline.

Flow through milking components: Water flow rates through a single, unrestricted milking unit was found to exceed 20 L/min. Increasing hose length, increasing the lift between the wash line and milk line, and extra air admission reduce the water flow rate through the unit for a given vacuum difference. When no attempt was made to balance

flow, great variation in water flow between units occurred. The flow capacity of the wash water draw line is determined by system vacuum, wash water draw line diameter and length, and the lift from the wash sink. When no air injection was applied to the wash manifold, excessive flow through the first several units caused the wash line to be drained of water with little or no flow through units at the end of the line. Placement of flow restrictors at each milking unit was shown to improve flow distribution.

Another factor affecting the distribution of water between units is timing of air injection applied to the wash manifold. When air injection is applied, the wash manifold is alternately filled and emptied. If the filling and emptying of the manifold is not complete in each cycle, significant variation can occur in the flow through units. Air injection was shown to improve the mechanical cleaning action in milking units and milk meters but made balancing flow distribution more difficult. Air injector open time on the wash line should be set long enough to push water out of the last unit, but no longer. The injector should be closed at least long enough to refill each unit. Increasing the closed time beyond this point further improved unit flow distribution. In general, the optimal timing cycle for even flow distribution through units is different for optimal slug action in the milk line.

A method called sequenced air injection was developed to optimize timing cycles on both the milkline and through milking units. With reference to Figure 1, both air injectors are closed to fill the wash manifold and draw enough water into the milkline to form a slug at the milk/wash valve. The air injector on the milkline (A2 in Figure 1) is then opened to create optimal slug flow in the milkline. This milkline injector is then closed and the air injector on the wash manifold (A1 in Figure 1) is opened for sufficient time to empty the wash manifold. This sequencing of air injection optimizes mechanical action in both the milkline and milking units, reduces flooding of the receiver and reduces the vacuum pump capacity required for cleaning.

Some equipment is designed to introduce steady air admission through milking units or milk meters during cleaning. This steady air admission did improve mechanical cleaning action of the components but made balancing unit flow more difficult and increased the vacuum pump capacity required for cleaning.

Cleaning assessment methods: Bacterial and milk soil attachment methods, described above, were shown to be repeatable and reliable for assessing cleaning. The ATP bioluminescence method correlated well with both protein assay methods in quantifying residual milk and standard plate counts in quantifying residual bacteria. When bacteria were allowed to incubate in the presence of a milk soil, the resulting residue was much more difficult to remove than either bacteria or milk soil alone.

There was no significant difference in bacteria removal in the temperature ranges from 43 to 54 °C. Improved removal was observed for temperatures above 60 °C. This effect corresponded to static tests in which the test bacteria remained viable at temperatures up to 54 °C. Interactive effects were found between different types of detergent and wall shear stress. Some detergents increased effectiveness with increasing shear while others were less effective at high shear. This was due to increased foaming of some detergents under conditions of high shear.

Discussion

The following procedure, based on the results of the laboratory experiments, has been developed to set up new systems and diagnose CIP circulation problems in exist-

ing systems. In addition to laboratory studies, this method has been implemented on a number of commercial dairies.

1) *Sketch and measure system:* Understanding the flow circuit is essential for CIP system diagnosis. A sketch should be made indicating the diameter and length of all lines and location of critical components such as receiver(s), wash sink(s), air injector(s), milk/wash valve(s) and any other ancillary equipment that is cleaned or used for cleaning. Observe a complete cleaning cycle and note whether air is being drawn in to the wash lines at the wash sink. Document methods of operation, including the cycles used, air injector timing, approximate water volume for each cycle and any manual or automatic operation of valves before or during cleaning.

2) *Set air injector open time:* The duration of air injection to the milkline should be calculated and adjusted as the first step in setup of the CIP system. The slug formed at the point of air injection should travel to the receiver without breaking. Measure the distance that the slug must travel from the point of air injection to the receiver. Divide the slug travel distance by the desired slug velocity to determine the air injector open time. Slug velocity for optimal mechanical action is between 7 and 10 m/s. Velocities at the lower end of this range will extend the time for a complete cleaning cycle which may be of benefit if the capacity of the milk pump is near its limit.

3) *Check slug velocity and adjust air admission rate:* Slug velocity should be measured using a vacuum recorder. The air admission rate to the milkline should then be adjusted to achieve the desired velocity. The rate at which air is drawn in through the milkline air injector determines the travel speed of the slug.

A vacuum recording performed simultaneously at two points on the milkline during cleaning is shown in Figure 2. The physical connection to the milkline is best done with a tee inserted in-line with a milk hose near the milk inlet. Sections of transparent tubing 3 to 6 meters in length should be used to connect to the recorder. These tubes

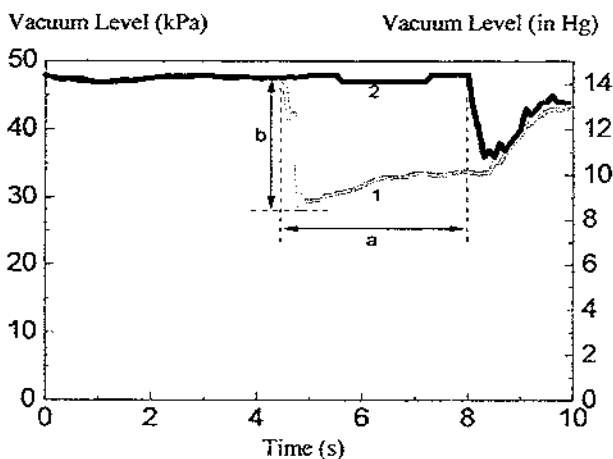

Fig. 2. Vacuum recording performed simultaneously at two points on the milkline during cleaning.

Abb. 2. Ganglinie der Vakuumentwicklung während der Reinigung an zwei verschiedenen Stellen der Milchleitung.

Table 1. Air injection rate to the milkline to produce 7 to 10 m/s slug velocity and vacuum drop across the milkline slug

Tabelle 1. Unterdruck und Luftzufuhr in die Milchleitung, um eine Pfropfen-Strömungsgeschwindigkeit von 7–10 m/s zu erzielen

Milkline Diameter	Air Injection Rate	Vacuum Drop
48 mm	390–910 L/m	18–37 kPa
60 mm	570–1300 L/m	15–32 kPa
73 mm	790–1700 L/m	13–29 kPa
98 mm	1300–2800 L/m	11–20 kPa

should be observed closely and bled often to prevent water from entering the recorder. It is advisable to leave the hoses detached except when a measurement is being taken. Moisture traps will very quickly fill with water and are not recommended. The two channels are recording the same slug as it moves through the milkline (points 1 and 2 in Figure 1). A single channel recorder can also be used but is not as convenient. The following information can be gained from these vacuum recordings:

Slug Velocity: Slug velocity can be calculated by dividing the distance between the two measurement points (e. g. distance between points 1 and 2 in Figure 1) by the time between vacuum drops (a in Figure 2). The test points should be at least 10 m apart for an accurate measurement. It is not uncommon to find 2 to 3 slugs in milking parlor milklines. The slug formed at the milk/wash valve is usually the largest slug and produces the largest vacuum drop. Clearly identify the initial slug before calculating slug velocity.

Vacuum Drop: A rapid vacuum drop is measured when the slug passes the test points. The vacuum drop across a slug (b) is a measure of the mechanical cleaning action produced. The recommended range of vacuum drop across the slug are given in Table 1. The vacuum drop should be near the maximum of the range at the beginning of slug travel. This vacuum drop across the slug will decrease slowly as it travels through the line due to slug decay and air entrainment. Inadequate vacuum drop across the slug indicates that the slug is very short (less than 1 m) and/or that excessive air is passing through the slug. A slow rate of vacuum drop indicates that the slug is moving slowly, usually because of excessive water in the pipeline or an excessively leaky milk/wash valve.

4) Set air injector closed (off) time: The amount of water drawn in during each cycle is determined by the amount of time the air injector is closed or off. The close time should be adjusted so the size of the slug reaching the receiver is just sufficient to wash the receiver. If the sanitary trap is flooding or excessive water is being transferred through the trap, the close time should be reduced. If the close time is reduced to the minimum value available on the controller and flooding still occurs, the capacity of the milk pump may need to be increased. Many parlors systems add water to the milkline in addition to that supplied by the milking units. This is normally not required to produce a slug. To avoid exceeding the capacity of the milk pump, all or most of the water used to form the slug should be drawn in through the milking units rather than directly into the milkline.

5) *Water flow through milking units:* The flow rate through milking units and milk meters should be measured using a receiving vessel installed in the milk hose between the milking unit and the milkline. If the highest and lowest water flow vary by more than 50% flow restrictors should be installed at the jetters unit to balance the flow. Preliminary results from field studies indicate that 3 L/m is sufficient to clean most milking units. While many units will clean at flow rates below 3 L/min, the risk of cleaning failure appears to increase. Some milk meters may require water flow rates higher than 3 L/min for effective cleaning. After flow distribution is balanced make sure that there is sufficient reserve in the wash sink so that the sink will not empty allowing air to enter the wash manifold. Air entry at the wash sink acts as an additional air injection location and reduces control of air injection timing.

6) *Final vacuum recorder testing and unit flow tests:* After the system has been adjusted according to steps 1 to 5, repeat vacuum recorder testing of slug flow. Check for the presence and strength of slug at the beginning, end and other critical locations in the milkline. Slight adjustment of air injector timing may be performed at this time. The air injector should close just before the slug enters the receiver jar. If the air injector remains open after the main slug reaches the receiver, excessive water will be carried through the sanitary trap. After fine adjustment of the air injector, recheck milking unit flow at critical locations including the first, last, and middle units on both sides of the parlor, and on any units with visible buildup.

Vacuum Pump Capacity and Control Strategies: New standards have been proposed for the minimum vacuum pump capacity required for milking (8). With proper system design and the control strategies described above, the vacuum pump capacity required for cleaning will be less than that for milking. The vast majority of milking systems will have sufficient vacuum pump capacity for cleaning if the vacuum pump capacity is greater than the air flow rate required to produce 7 m/s slug velocity in milkline plus about 56 L/min per unit for steady air admission through claw vents, system leaks and pulsation.

Remarks

Both laboratory studies and field experience on an increasing number of commercial dairy farms show that the vacuum pump requirements for cleaning can be less than that for the new recommendations for milking. If milking machine CIP systems are designed and operated properly, significant energy savings can result from both reduced hot water use and reduced vacuum pump capacity. Improper use of air injection is a major cause of cleaning failures and excessive vacuum pump sizing. The methods presented here can be used to properly locate and adjust air injection to assure efficient and effective circulation of cleaning solutions. A properly functioning CIP system aids in the production of consistently high milk quality, less trouble for the dairy operator and fewer callbacks for the equipment dealer.

The milk soil application method produced a tenacious deposit that provided enough resistance to removal and repeatability to be usable for detecting differences between detergents. The ATP bioluminescence method was found to correlate well with other assessment methods in laboratory tests as well as a useful relative indicator of cleaning in field applications. It can be a useful tool, used in combination with flow testing to identify locations of cleaning failures.

References

1. Australian Standards Organization: Standard No. AS 2844.2 (1986)
2. Govier, G. W. and K. Aziz: *The Flow of Complex Mixtures in Pipes*. Van Nostrand Reinhold Company, New York, 792 pp. (1972)
3. Hetsroni, G.: *Handbook of Multiphase Systems*. Hemisphere Publishing Corp., New York (1982)
4. Grasshoff, A. und D. J. Reinemann: „Zur Reinigung von Milchsammelleitungen mit Hilfe einer 2-Phasen-Strömung“. *Kieler Milchwirtschaftliche Forschungsberichte*, 45, 205–234 (1993)
5. Lind, O.: Cleaning-in-place (CIP) of the milking machine. Physical forces. In Proc. Seminar on Machine Milking and Mastitis, Aarhus, Denmark, August 6–8 1990. pp 162–173 (1990)
6. Peebles, R. W. und D. J. Reinemann: “Control Strategies to Reduce the Vacuum Pump Capacity Required for Cleaning Milking Systems”. Paper No. 953274, Written for Presentation at the 1995 International Meeting Sponsored by the American Society of Agricultural Engineers, June 18–23, 1995, Chicago, Illinois (1995)
7. Reinemann, D. J. and A. Grasshoff: “Two phase cleaning flow dynamics in air injected milklines”. *Transactions of the ASAE*, Vol. 37, No. 5, pp. 1531–1536 (1994)
8. Reinemann, D. J. and G. A. Mein: “Sizing Vacuum Pumps for Cleaning Milking Systems”. Proc. National Mastitis Council Annual Meeting, February 19–22, Fort Worth Texas (1995)
9. Reinemann, D. J. and R. W. Peebles: “Flow Dynamics in Milking Parlor Clean-In-Place Systems”. ASAE Paper No. 943567, Presented at the International Winter Meeting of the American Society of Agricultural Engineers, Atlanta, Georgia, December 13–16, 1994 (1994)
10. Reinemann, D. J., A. C. L. Wong, and E. Rabotski: “Interaction of chemical, thermal and physical actions on the removal of bacteria from milk contact surfaces”. ASAE paper No. 933536, Presented at the 1993 Winter meeting of the American Society of Agricultural Engineers, Chicago, Illinois, USA (1993)
11. Reinemann, D. J., A. Grasshoff, and A. C. L. Wong: “Clean-ability Assessment of Milking Systems”. ASAE paper No. 923540, Presented at the 1992 Winter meeting of the American Society Agricultural Engineers, Nashville, Tennessee (1992)
12. Tragardh, C. and I. von Bockelmann: Mechanical cleaning effect and pressure drop of air-water flow in horizontal glass tubes (vacuum dairy pipelines), *Journal of Food Process Engineering*, Vol. 3, pp. 77–90 (1980)
13. Wallis, G. B.: *One Dimensional Two-phase Flow*. McGraw Hill, New York, 408 p. (1969)
14. Wolters, G. M. V. H., and J. G. P. Verheij: Energie-efficient reinigen melkwinningssaparatuur, Publikatie nr. 85 Proefstation voor de Rundveehouderij, Schapenhouderij en Paardenhouderij (PR), Waiboerhoeve, Regionale Onderzoek Centra (ROC's), October 1993, pp. 31 (1993)

Corresponding author: Douglas J. Reinemann, University of Wisconsin, 460 Henry Mall, Madison WI 53706