

Low Cost Parlors For Wisconsin and Minnesota Dairy Producers



Figure 1. Retrofit parlors have proven to be a low cost way for Wisconsin dairy producers to adopt parlor technology into their operations. This parlor cost was under \$34,000.

The transition from the tie stall barn milking system to a free stall housing and parlor milking system has been occurring on Minnesota and Wisconsin farms for several years. However, the adoption of milking parlors on smaller family dairy farms has been slow due to the large costs involved with building a traditional parlor and freestall setup.

Many family dairy farms want to maintain a herd size that avoids hiring extra farm labor. To accomplish this the existing milking facilities need to be modernized. However, the cost of a new parlor, freestall barn and a manure handling system is usually cost prohibitive when trying to spread the investment over 60-175 cows

At this point producers reach a crossroad and must decide which future direction they want

their operation to take. Their options usually include: remodeling the present barn; moving the cattle out of the traditional barn and into a new freestall barn and parlor at a new location; get out of dairying; or build a new freestall barn and a retrofit parlor inside their present stall barn. Many have found the last option as being the most attractive in meeting their future goals.

Advantages of Retrofitting Parlors In Barns

- Cost savings of 25-50% over new convention parlors with a separate building.
- Savings can be put into building a new freestall facility to improve cow comfort.
- Provides an alternative use for empty dairy barns that remain on the property tax rolls.
- Allows for phasing in milking facility upgrades over time, reducing stress and interest costs.

- Milking in a parlor creates a safer and more comfortable environment for the milker.
- Doubles the number of cows milked/person per hour as compared to tie stall milking systems. The Dairy Modernization Team would like to provide information on low cost parlors to the over 10,000 dairy farms in Wisconsin and Minnesota that could benefit from their use. Many dairy producers have already demonstrated that retrofit parlors can be an attractive option in modernizing their milking facility. In some cases the retrofit parlor serves as a temporary milking facility and in many others it is built to serve as the long term milking facility.



Figure 2. Innovative crowd gates have been developed by producers to allow the gates to work around king beam posts in stall barns.

Dairy producers have found significant cost advantages in building retrofit parlors in an existing stall barn. Cost savings of up to 25-50% have been realized when using the present milking system and the building shell that already exists in the stall barn. The center driveway in a stall barn works well for a holding area and other parts of the barn can be used for housing extra cows, maternity pens or a special needs area work area.

Dairy producers have saved in excess of \$40,000 by utilizing their old stall barn as their milking center. These cost savings can make a

nice down payment for a new freestall barn. The benefits of improved milk production and cow comfort are well documented when moving cows to a new freestall barn.

Many producers also like the idea of being able to keep their debt load down and make improvements to their milking facilities over a period of time instead of trying to pay for the facility improvements all at one time.

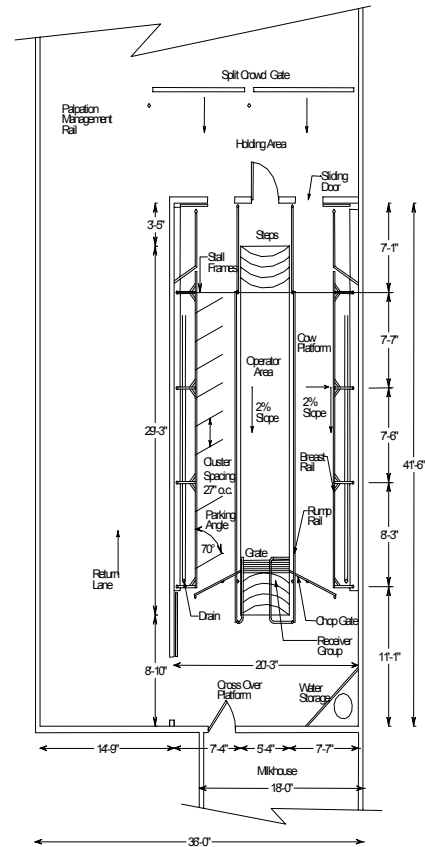

Figure 3. Retrofit parlors with return alleys can fit into most Wisconsin barns that are 32-36' wide.

The UW-Extension Dairy Modernization Team has prepared this fact sheet and a new CD on low cost parlors to help demonstrate the application of retrofit parlors on Wisconsin and Minnesota family dairy farms. It will be available on November 15, 2001 from the Center for Dairy Profitability. For ordering

information go to the Center for Dairy
Profitability Web page @ cdp.wisc.edu or
contact Arlin Brannstrom @ 608 265-3030.

Mark Mayer
Green County
UW-Extension

David W. Kammel
Biological Systems Engineering
UW-Madison