

# MILKING EQUIPMENT INSTALLER MANUAL

2003 REVISION

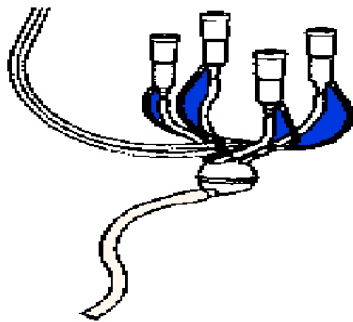

**WISCONSIN DEPARTMENT OF AGRICULTURE,  
TRADE AND CONSUMER PROTECTION**

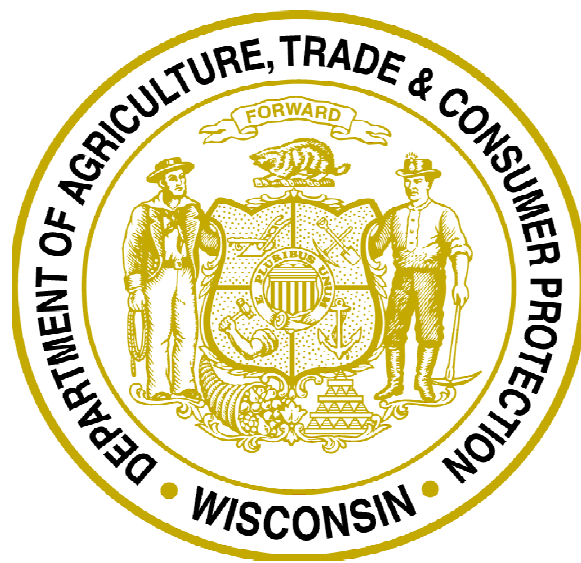

## TABLE OF CONTENTS

Click on a title to go to that page

	Page
<a href="#">Food Safety Consultant Map</a> .....	1
<a href="#">Dairy Farm Equipment Installer Contact List</a> .....	2
<a href="#">Requirements For Milking Equipment Plans (F-Fd-39)</a> .....	3
<a href="#">Application for Milk Handling Equipment (F-Fd-31)</a> .....	4-5
<a href="#">Wisconsin CIP Milking System Requirements (F-Fd-32)</a> .....	6
<a href="#">Milking System Sizing (F-Fd-32, page 2)</a> .....	7
<a href="#">Wisconsin Dairy Farm Milk Precooler Requirements (F-Fd-36)</a> .....	8-11
<a href="#">Wisconsin Requirements For Locating Air Injectors (F-Fd-33)</a> .....	12
<a href="#">Wisconsin Milkhouse Construction Requirements (F-Fd-34)</a> .....	13
<a href="#">Wisconsin Bulk Tank Installation Requirements (F-Fd-34, page 2)</a> .....	14
<a href="#">Wisconsin Requirements For Mini-Milkhouse/Pumphouse (F-Fd-35)</a> .....	15
<a href="#">Wisconsin Milking Parlor Construction Standards (F-Fd-114)</a> .....	16-17
<a href="#">Wisconsin Requirements For Direct Tanker Shipping (F-Fd-71)</a> .....	18-19
<a href="#">Additional Considerations For Direct Tanker Shipping (F-Fd-70)</a> .....	20-22
<a href="#">Direct Tanker Milk Shipping Supplemental Application (F-Fd-258)</a> .....	23-25
<a href="#">Questions and Answers From March 1997 Installer Meetings</a> .....	26-29
<a href="#">Questions and Answers From December 1999 Installer Meetings</a> .....	30-31
<a href="#">Appendix A - 3-A Accepted Practices 606-04</a> .....	1-18
<a href="#">Appendix B - ASAE Standard S518.2</a> .....	389-394
<a href="#">Appendix C - ASAE Standard EP445.1</a> .....	311-316

### DFS Food Safety Consultant Map

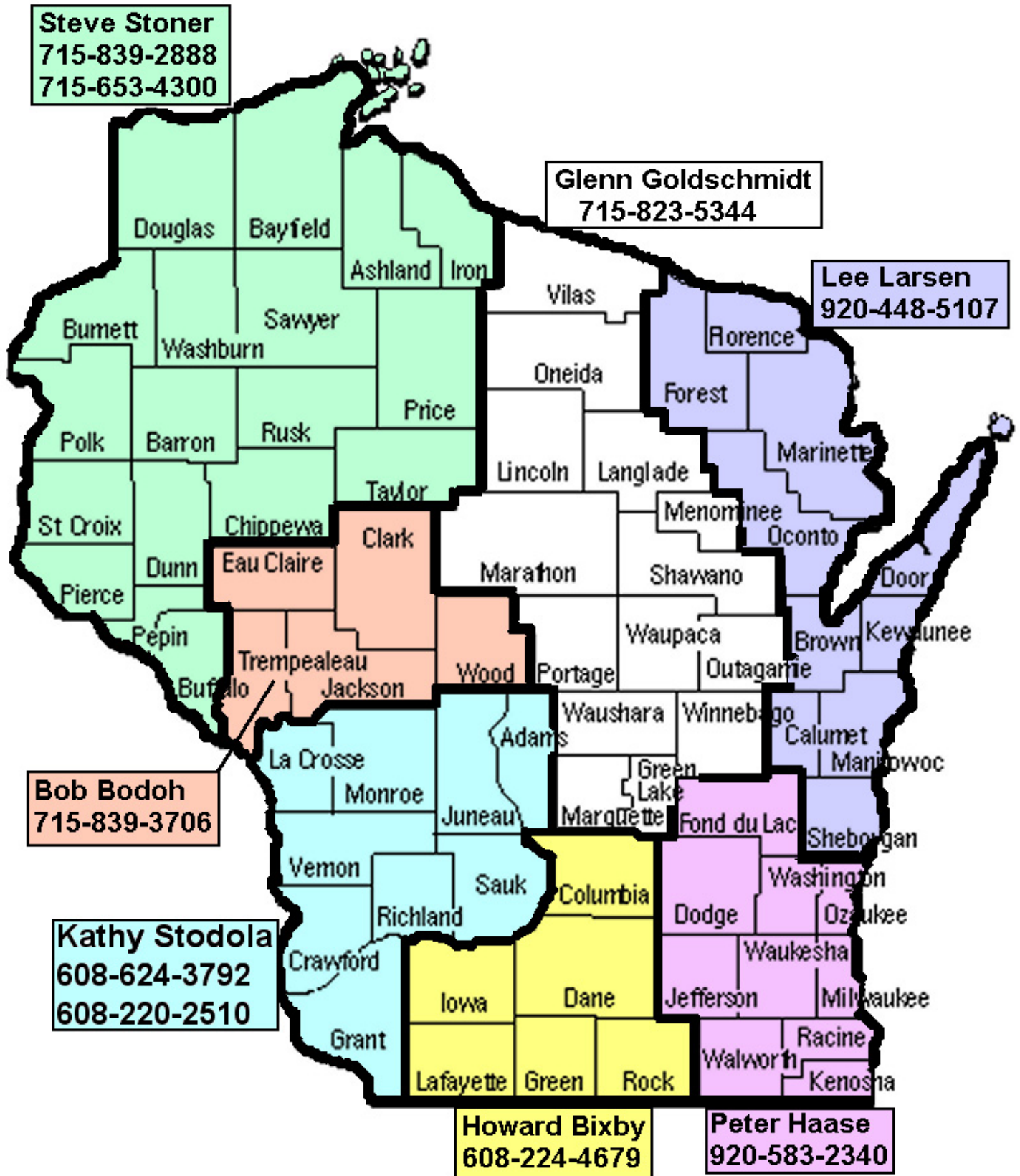

Exceptions: Assignments for Fond Du Lac County  
Lee Larsen: Baker Cheese (55-428), Saputo (55-003), Saputo (55-341)  
Peter Haase: All other responsibilities in Fond Du Lac County

## Contact List For Dairy Farm Equipment Installers

<p><b>Septic Systems</b></p>	<p><b>Wisconsin Dept. of Commerce Division of Safety and Buildings Private Sewage 608-266-3151</b></p>
<p><b>Plumbing and Cross Connections</b></p>	<p><b>Wisconsin Dept. of Commerce Division of Safety and Buildings Plumbing 608-266-3151</b></p>
<p><b>ASAE Standards</b></p>	<p><b>American Society of Agricultural Engineers 2950 Niles Rd. St. Joseph, MI 49085 269-429-0300 / 800-606-2304</b></p>
<p><b>3-A Standards and Accepted Practices</b></p>	<p><b>International Association for Food Protection 6200 Aurora Avenue, Suite 200W Des Moines, IA 50322-2864 515-276-3344 <a href="http://www.foodprotection.com">www.foodprotection.com</a></b></p>
<p><b>Helpful guidelines on milking parlors, milk precoolers, water heater sizing, etc.</b></p>	<p><b>The Dairy Practices Council 51 E. Front St., Suite 2 Keyport, NJ 07735 Tel/Fax 732-203-1947 <a href="http://www.dairypc.org">www.dairypc.org</a> *Also check with your county UW Extension Agricultural Agent</b></p>
<p><b>Training in milking system design, sizing, and testing</b></p>	<p><b>UNIVERSITY OF WISCONSIN CALC OUTREACH OFFICE 608-263-1672</b></p>
<p><b>DATCP-Division of Food Safety</b></p> <p><b>Statewide Equipment Approvals</b></p> <p><b>Statewide Policy Questions</b></p>	<p><b>DATCP-Division of Food Safety Central Office Byron Dennison 608-224-4715</b></p>
<p><b>DATCP-Division of Food Safety</b></p> <p><b>Plan Review</b></p> <p><b>Equipment Review</b></p> <p><b>Policy Questions</b></p>	<p><b>See the Food Safety Consultant area map</b></p>



## WISCONSIN REQUIREMENTS FOR MILKING EQUIPMENT PLANS

Plans, when required, must be submitted to the DATCP – Division of Food Safety and be reviewed prior to installing. All installation, modification or replacements shall meet applicable requirements.

- ◆ Complete pipeline system installation (new or used systems)  
Plan and \$25.00 fee required.
- ◆ Milk pre-cooling equipment (new or used)  
Plan and \$25.00 fee required.
- ◆ Bulk tank installation (new or used tanks)  
Plan required. No fee required.
- ◆ Modification or replacement of existing pipeline systems or components  
Plan and \$25.00 fee required if the modification or replacement changes any of the following:
  - Size of milking line or main vacuum line
  - Length of milking line
  - Size of number of receiver jar inlets
  - Number of pipeline slopes
  - Number of milker units
  - Number of milker units per milk line slope
  - CFM of vacuum needed
  - Size of vacuum pump if CFM is less than previously installed
  - Utilization of direct tanker shipment of milk
- ◆ New milking parlors and modifications of milking parlors  
Plan not required. Plan is recommended. No fee required if plan is submitted.
- ◆ New milking parlors and modification of milking parlors  
Plan not required. Plan is recommended. No fee required if plan is submitted.



Wisconsin Dept. of Agriculture, Trade & Consumer Protection  
Division of Food Safety

## Application for Milk Handling Equipment

**Please Mail Directly to:** 200 N. Jefferson, Suite 146-A  
Green Bay, WI 54301

- Wisconsin regulations require a plan to be submitted and reviewed before installation of milking and milk handling equipment.
- Only plans that are complete and legible will be reviewed.
- A fee of \$25 for pipeline milker plans must accompany this form or plans will be returned. No fee is charged for bulk tank plans.
- The review of your plan and /or application is based on Wisconsin regulations and standards in effect at this time.
- This installation will be inspected at the time of the next inspection for compliance with Wisconsin regulations and standards. Modification of this installation may be required at some future date as regulations and standards are updated.

### TYPE OF INSTALLATION

<input type="checkbox"/> NEW	<input type="checkbox"/> MODIFICATION
------------------------------	---------------------------------------

### TYPE OF EQUIPMENT

<input type="checkbox"/> BULK TANK	<input type="checkbox"/> PRECOOLER
<input type="checkbox"/> PIPELINE MILKER	<input type="checkbox"/> SILO
<input type="checkbox"/> DIRECT TANKER (Requires Supplementary Application)	
<input type="checkbox"/> Other – explain	

### TYPE OF FACILITY

<input type="checkbox"/> NEW	<input type="checkbox"/> EXISTING
------------------------------	-----------------------------------

### MILKING AREA

<input type="checkbox"/> STANCHION BARN	<input type="checkbox"/> MILKING PARLOR
<input type="checkbox"/> SWING PARLOR	<input type="checkbox"/> FLAT BARN PARLOR
<input type="checkbox"/> OPEN AIR PARLOR	

### WDATCP USE ONLY

PAYMENT RECEIVED 129-68-7000	
REVIEWER	DATE
REV COMMENTS	DATE STAMP
-----	
-----	
-----	
-----	

**INSTALLER MUST SIGN THIS STATEMENT UPON  
COMPLETING INSTALLATION AND FORM SHALL  
BE POSTED WITH INSPECTION REPORTS IN MILK HOUSE**

I hereby certify that I have installed the equipment as described on this application and in compliance with Chapter ATCP 60, Wisconsin Administrative Code

SIGNATURE OF EQUIPMENT INSTALLER OR REPRESENTATIVE

DATE OF COMPLETION

Please Print

### INSTALLER INFORMATION

NAME		
MAILING ADDRESS		
CITY	STATE	ZIP
PHONE #	SIGNATURE	DATE

### DAIRY PLANT INFORMATION

DAIRY PLANT NAME		
PLANT LOCATION	PLANT NO	PATRON NO

### PRODUCER INFORMATION

NAME		
DBA(FARM NAME)		
MAILING ADDRESS		
CITY	STATE	ZIP
COUNTY NAME & #	TOWNSHIP NAME & #	SECTION
PHONE NUMBER		
PRODUCER'S SIGNATURE		DATE

Continue on Reverse Side

**INSTRUCTIONS**

- All blanks that apply to this installation must be completed
- This application must be accompanied by a detailed legible drawing of the milk system showing the following:
 

1. Bulk Milk Tank	5. Floor Drain	9. Receiver Group	13. Filter
2. Double Wash Vats	6. High Point	10. Weigh Jars	14. Vacuum Pump
3. CIP Pipeline Vat	7. Vacuum Test Port	11. Pipeline Inspection Port	15. Wash Flow
4. Hand Wash Sink	8. Air Injector	12. Milk Precooler	16. Wash Manifold

**FABRICATION OF MILKING SYSTEM**

**A. Milkline**

1. Material(s)	7. Percent slope <input type="checkbox"/> .8% (1 inch/10 feet)
2. Diameter	<input type="checkbox"/> 1.0% (1¼ inch/10 feet) <input type="checkbox"/> 1.2% (1½ inch/10 feet)
3. Length	<input type="checkbox"/> 1.5% (2 inch/10 feet) <input type="checkbox"/> 2.0% (2½ inch/10 feet)
4. WELDED <input type="checkbox"/> GASKETED <input type="checkbox"/>	8. HIGH LINE <input type="checkbox"/> LOW LINE <input type="checkbox"/>
5. Number of Units	9. Max. Height from Floor
6. Max. Units Per Slope	10. Units Washed in PARLOR <input type="checkbox"/> MILKHOUSE <input type="checkbox"/>

**B. Receiver**

1. Number of Receiver Inlets \_\_\_\_\_
2. Size of Receiver Milk Inlet(s) \_\_\_\_\_
3. Size of Receiver Vacuum Inlet \_\_\_\_\_

**C. Other system components with vacuum requirements (Fill in those that apply)**

ITEM	QUANTITY	ADDITIONAL VACUUM REQUIREMENTS

**D. Vacuum System**

1. Main Airline Material \_\_\_\_\_ Diameter \_\_\_\_\_ Length \_\_\_\_\_
2. Pulsator Line Material \_\_\_\_\_ Diameter \_\_\_\_\_ Length \_\_\_\_\_
3. Automatic Drains in Pulsator Lines YES  NO
4. Vacuum Pump(s) Brand \_\_\_\_\_ Model(s) \_\_\_\_\_ Motor hp \_\_\_\_\_
5. Total Vac Pump Capacity \_\_\_\_\_ CFM/ASME at Normal Operating Level of \_\_\_\_\_ in. Hg.
6. Vacuum Regulator Brand \_\_\_\_\_ Model \_\_\_\_\_
7. Other (specify) \_\_\_\_\_

**E. Milk Cooling and Storage System**

1. Pre-Cooler Brand \_\_\_\_\_ Type \_\_\_\_\_ Model \_\_\_\_\_  
 Number of passes in plate cooler \_\_\_\_\_  
 Coolant Well water single use  Recirculated water  Recirculated glycol   
 Type of coolant preservative used \_\_\_\_\_
2. Bulk Milk Tank Brand \_\_\_\_\_ Model \_\_\_\_\_ Capacity \_\_\_\_\_  
 Date of Manufacture \_\_\_\_\_  
 Bulk tank temperature recorder provided? (Required on tanks manufactured after 1/1/2000) YES  NO
3. Type of cleaning MANUALLY CLEANED  CIP
4. Distances from bulk milk tank to walls, ceiling and equipment provided on plan? YES  NO
5. Silo Brand \_\_\_\_\_ Model \_\_\_\_\_ Capacity \_\_\_\_\_
6. Tanker Brand \_\_\_\_\_ Model \_\_\_\_\_ Capacity \_\_\_\_\_

**F. Water Heating Equipment**

1. Water heating system has been designed to be adequate for all milkhous operations YES  NO
2. Capacity of water heating system is \_\_\_\_\_ Gallons

**G. Physical Separation of Wash Systems (Lines) From**

1. Milking System During Milking YES
2. Milk Tank During Milk Storage YES



## WISCONSIN C.I.P. MILKING SYSTEM REQUIREMENTS

Wisconsin Department of Agriculture,  
Trade & Consumer Protection  
Division of Food Safety

1. **Milkline Support:** Support the C.I.P. milking pipeline at least every 10 feet so the entire pipeline and fittings remain in constant alignment and position. Do not hang the pipeline from the ceiling, but supported on posts extending from the floor to the ceiling, on barn posts, or in the stanchion supports. Use pipeline supports of stainless steel or other hanger material designed to reduce the possibility of electrolytic action within the pipeline.
  2. **Milkline Slope:** Slope the C.I.P. milking pipeline to be self-draining and have a continuous slope of at least one-inch per ten feet from a high point. The highest point of the milk pipeline shall not exceed seven feet above the cow platform. Provide pitch of at least 1/2 inch per ten feet on the vacuum lines in the direction of airflow.
  3. **Stall Cocks:** Install stall cocks (milk inlet nipples) on the upper half of the line.
  4. **Milk Pump:** Mount the milk pump for ease of maintenance and inspection. The department recommends weekly inspection of the milk pump.
  5. **CIP Racks:** Ensure all clean-in-place racks and appurtenances are removable from the two-compartment wash sink to provide two unobstructed compartments for washing and rinsing of all other equipment or provide a third wash sink.
  6. **Receiver Jar Pits:** Receiver jars installed in pits shall meet all general milkhouse construction requirements, and the following additional requirements.
    - Size the pit for adequate access for inspection of receiver jar components
    - Provide a method to prevent milkhouse floor wastes from entering the pit through the installation of a raised lip or concrete curbing.
    - Provide adequate lighting above the pit
    - Slope the pit floor to drain and effectively remove all liquid wastes to protect the receiver group. Removal of liquid waste via a sump is acceptable; do not connect the drain to a sanitary disposal system.
  7. **Plumbing Code:** To prevent back-siphoning, the Wisconsin Plumbing Code requires that the water inlet of an automatic washer or water hose inlet terminate at least twice its inside diameter above the flood rim of the wash sink.
  8. **Water Heating Capacity:** Water heating capacity shall be adequate for all milkhouse operations. The producer or installer shall determine the water heating capacity needed. Guidance for sizing water heating systems can be obtained from The Dairy Practices Council publication number 58; "Guidelines For Sizing Dairy Farm Water Heater Systems"<sup>1</sup> or from a milking equipment installer..
  9. **Product Adulteration:** Prevent adulteration of the milk supply, with water or cleaning solutions or sanitizer during product storage and the cleaning, rinsing or sanitizing operations.
  10. **Automatic drains:** Install automatic drains where needed to make all vacuum lines drain completely, i.e., at the bottom of all risers.
  11. **Access for Inspection:** Provide a removable elbow on all welded lines to provide access for inspection. Install this elbow in the wash solution return line nearest the milk house.
  12. **Sample Welds:** Good manufacturing practices recommend that a sample weld be made at the start of each day's welding and be available at the producer location for inspection. Satisfactory welds do not required grinding or polishing.
  13. **Vacuum Sizing:** See the instructions on the back of this sheet for sizing the vacuum system, pulsator airline, main airline, and milkline. **Note:** The instructions are based on ASAE Standard S518. They are only recommendations and do not guarantee proper system sizing.
- 3-A Accepted Practices, ASAE Standards, and DATCP recommend that the completed system be tested as described in ASAE Standard EP445 to verify proper performance.**

<sup>1</sup> Order From: The Dairy Practices Council  
51 E. Front Street, Suite 2  
Keyport, NJ 07735  
Telephone/Fax: (732) 203-1947  
Or online at [www.dairyipc.org](http://www.dairyipc.org).

# MILKING SYSTEM SIZING

## 1. VACUUM SYSTEM SIZING

### ASAE Standard S518, Annex A

- Allow 35 CFM for basic effective reserve
- Add 3 CFM for each milker unit
- Add 0.5 CFM for each milk meter (or manufacturer specification if different than 0.5 CFM)
- Add CFM for other vacuum equipment according to manufacturer specification
- Add CFM for cleaning if needed based on S518, Annex A3

## 2. PULSATOR AIRLINE SIZING

### ASAE Standard S518, Section 9

**Table 2 - Recommended minimum sizes for looped pulsator airlines**

Number of units	Pipe diameter <sup>1</sup>
1 to 14	50 mm (2 in.)
15 or more	75 mm (3 in.)

<sup>1</sup> metric = nominal ID. inch = US pipe size

## 3. MAIN AIRLINE SIZING

### ASAE Standard S518, Annex B

Vacuum pump capacity L/min free air	Approx. length of main airline (m of straight pipe)			
	5	15	20	25
1500	50 mm	75	75	75
2000	75	75	75	75
3000	75	75	75	100
4000	100	100	100	100
5500	100	100	100	100
7000	100	150	150	150
8500	150	150	150	150
10000	150	150	150	150

Vacuum pump capacity ft <sup>3</sup> /min free air	Approx. length of main airline (feet of straight pipe)						
	10	20	40	60	80	100	200
50	2 in.	2	3	3	3	3	3
70	3	3	3	3	3	3	3
100	3	3	3	3	4	4	4
150	4	4	4	4	4	4	4
200	4	4	4	4	4	4/6	6
250	4	4	6	6	6	6	6
300	6	6	6	6	6	6	6
400	6	8	6	6	6	6	6

NOTE - The main airline is defined as the pipeline between the vacuum pump and the sanitary trap near the receiver. These calculations are based on a maximum vacuum drop of 2 kPa (0.6 in. Hg) between the vacuum pump and receiver. The maximum air flowrate is normally from the vacuum regulator to the pump. Whenever additional air enters the milking clusters during milking, however, the maximum air flowrate is from the receiver to the vacuum pump.

These tables include an allowance for the equivalent length (m or feet of straight pipe) of one distribution tank, one sanitary trap and eight elbows. If the system includes more than eight elbows, then use the next pipe length column to the right for every three additional elbows. In systems with two receivers, the theoretical maximum air flowrate in the two separate airlines between the distribution tank and the sanitary traps may be halved. The size of these split lines can be reduced according to the values in the table corresponding to half the vacuum pump capacity.

## 4. MILKLINE SIZING

### ASAE Standard S518, Annex C

#### Design guidelines and recommendations for maximum number of units per milkline slope to assume stratified flow

- These guidelines are based on the fastest-milking 5% of cows in the US and France, i.e. mean peak milking rate of 5.5 L/min (12 lb/min) per cow.
- Steady air admission within the range 10 to 20 L/min (0.35 to 0.7 ft<sup>3</sup>/min) per unit through claw air vents and air leaks is assumed in the calculations.
- The guidelines assume that the cross-sectional area of the milkline(s) is not substantially reduced by fittings.
- A slope of 0.8% is equivalent to 8 mm drop per m of run (1 in. drop in 10 ft).
- A slope of 1.2% is equivalent to 12 mm drop per m of run (1.5 in. drop in 10 ft).

**Table C1 - Milking parlors: looped milkline with units attached simultaneously by careful operators. Transient air admission of 100 L/min (3.5 ft<sup>3</sup>/min) per milkline slope**

Nominal milkline size	Maximum number of units per slope				
	0.8%	1.0%	1.2%	1.5%	2.0%
48 mm (2 in.)	2	3	3	4	5
60 mm (2.5 in.)	6	6	7	9	10
73 mm (3 in.)	11	13	14	16	19
98 mm (4 in.)	27	30	34	38	45

**Table C2 - milking parlors: looped milkline with units attached simultaneously by typical operators Transient air admission of 200 L/min (7 ft<sup>3</sup>/min) per milkline slope.**

nominal milkline size	Maximum number of units per slope				
	0.8%	1.0%	1.2%	1.5%	2.0%
48 mm (2 in.)	1	1	2	2	3
60 mm (2.5 in.)	4	4	5	6	8
73 mm (3 in.)	9	10	12	13	16
98 mm (4 in.)	24	27	31	36	41

**Table C3 - Stanchion barns: looped milklines with units attached every 30 seconds per slope Transient air admission of 100 L/min (3.5 ft<sup>3</sup>/min) per milkline slope.**

Nominal milkline size	Maximum number of units per slope			
	0.8%	1.0%	1.2%	1.5%
48 mm (2 in.)	2	3	3	4
60 mm (2.5 in.)	6	9	*(9)	*(9)
73 mm (3 in.)	*(9)	*(11)	*(13)	*(16)

NOTE - Asterisk indicates an unlimited number at units when they are attached at 30 s intervals. If more than one operator is attaching units on the same slope, the attachment rate may be quicker than one unit every 30 s. if so, then the guideline figures in table C1 could be used.

Wisconsin Department of Agriculture, Trade & Consumer Protection, 2811 Agriculture Drive, Madison, WI 53718  
This institution is an equal opportunity provider.



## WISCONSIN DAIRY FARM MILK PRE-COOLER REQUIREMENTS

### ALL PRE-COOLERS-GENERAL REQUIREMENTS

1. A plan shall be submitted to and reviewed by DFS before installing a pre-cooler.
2. The installation shall comply with 3-A 606-05 and Ch. ATCP 60 Wisconsin Administrative Code.
3. Pre-coolers shall drain completely- provide automatic drains where needed. Multiple pass coolers shall be designed to allow drainage of all the passes that can trap water.
4. Make pre-coolers easy to access for inspection and cleaning. Provide any tools needed for disassembly near the cooler.
5. Single use cooling water sources shall comply with ATCP 60.08.
6. Recirculated coolant shall be tested and found safe every 6 months.
7. Glycol coolant shall be food grade.
8. Recirculated coolant systems shall protect the coolant from contamination.
9. Provide a sampling valve on recirculated cooling systems.
10. Provide a drip deflector on the swing pipe if it passes through the bulk tank cover.
11. Locate pre-coolers in a proper area, not in milking barns or animal housing areas.
12. For plumbing requirements, see next page.

### PLATE PRE-COOLERS-ADDITIONAL REQUIREMENTS

1. Plate pre-coolers shall comply with 3-A Standard 11-05.
2. Plate pre-coolers installed after November 1990, are required to have end plate bolt cutouts.
3. Mount plate pre-coolers a sufficient distance from the wall with unobstructed access to the moveable end plate.
4. Provide easy to disassemble connections on the end plates.
5. Plate pre-coolers shall allow opening to the width of one plate or 15 inches, whichever is less.
6. Ceiling mounted units shall be easy to take down for inspection.
7. Provide a milk filter between the receiver jar and pre-cooler– change filters before milking and before CIP.
8. For plumbing requirements, see next page.

### TUBE IN SHELL COOLERS- ADDITIONAL REQUIREMENTS

Tube in shell pre-coolers shall comply with 3-A Standard 12-06.

For plumbing requirements, see next page.

### CUBE TYPE COOLERS AND RECEIVER JAR COOLERS - ADDITIONAL REQUIREMENTS

For plumbing requirements, see next page.

## WISCONSIN DAIRY FARM MILK PRE-COOLER REQUIREMENTS

### PLUMBING REQUIREMENTS FOR ALL PRE-COOLERS

1. If there are no valves in the discharge line from the pre-cooler, back flow prevention is not required.
2. If there is a valve in the line downstream from the pre-cooler, back flow prevention is required on the water supply line.
3. The pre-cooler discharge line shall have no submerged inlets or cross connections to other water lines, regardless of any back flow prevention in the water supply line.

### Acceptable Plumbing-Outlet Line Not Under Pressure

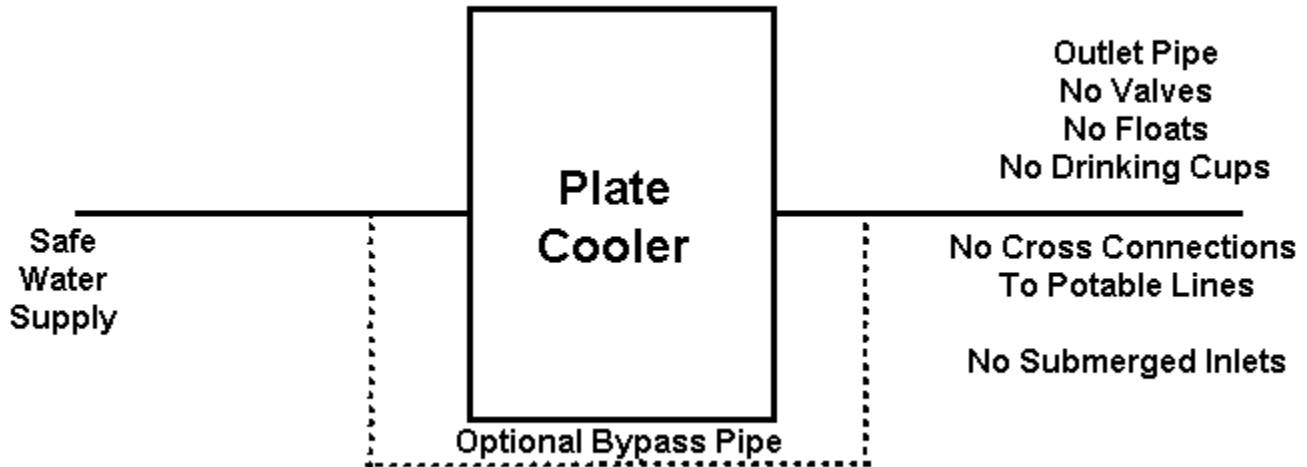

Note: Valves may be located in the water supply and bypass lines

### Acceptable Plumbing-Outlet Pressurized

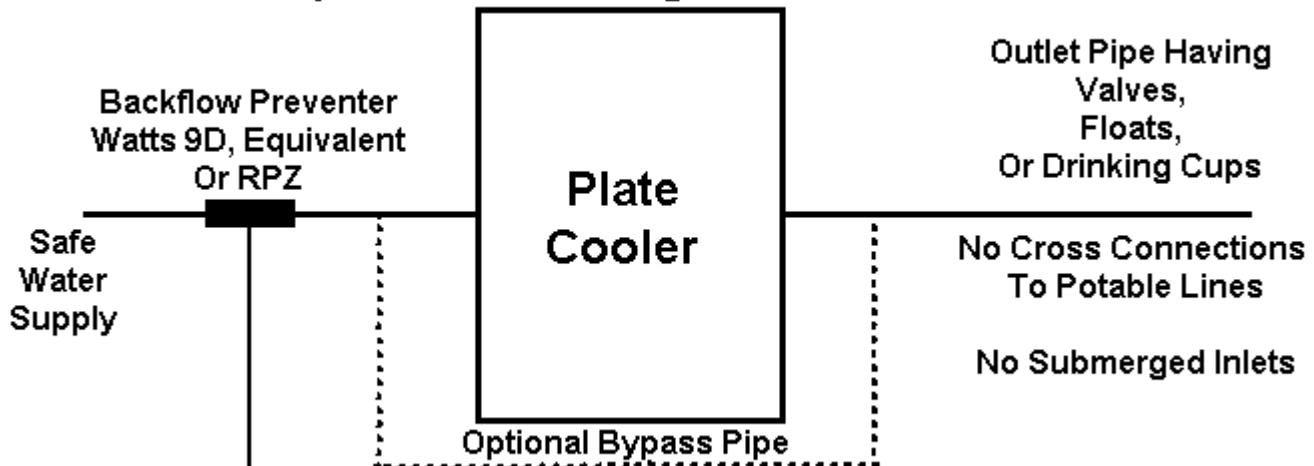

Note: Valves may be located in the water supply and bypass lines

## **WATER RECLAIMED FROM HEAT EXCHANGER PROCESSES**

Potable water utilized for heat exchange purposes in plate or other type heat exchangers or compressors on dairy farms may be salvaged for the milking operation if the following criteria are met. **Note:** Reclaimed water for milking operations is defined as any equipment or personnel cleaning operations, hot water production, CIP make-up, or any water use that may contact milking equipment.

1. The water shall be stored in a storage vessel properly constructed of such material that it will not contaminate the water supply and be designed to protect the water supply from possible contamination.
  - Acceptable materials include those normally found in water distribution systems that also allow the system to be effectively cleaned if contamination of the system occurs.
  - Protection of the water supply in the tank includes the use of tight fitting or overlapping covers, placement of the tank in an environment that will not affect the integrity of the tank and protects the water supply from any potential source of contamination.
  - The storage vessel shall be equipped with a drain and access point to allow for cleaning.
2. No cross-connection shall exist between this supply and any unsafe or questionable water supply or any other source of contamination.
3. The outlet of the plate cooler shall be provided with backflow protection prior to the storage tank and must not reconnect with the potable water distribution system.
4. There are no submerged inlets through which this supply may be contaminated.
5. The water shall be of satisfactory organoleptic quality and shall have no off flavors or odors.
6. The water shall be bacteriologically safe. Test results shall be kept at the farm for review.
  - Samples shall be collected and analyzed prior to initial approval and semi-annually thereafter. See the reverse for the testing criteria.
7. Approved chemicals, such as chlorine, with a suitable retention period, may be used to suppress the development of bacterial growth and prevent the development of tastes and odors.
  - When chemicals are added, a monitoring program for the added chemicals shall be maintained.
  - Additionally, the chemical addition process shall not add substances that will prove deleterious to the use of the water or contribute to product contamination.
8. If the water is to be used for the sanitizing of teats or equipment (backflush systems), approved sanitizers, such as iodine may be added by an automatic proportioning device located downstream from the storage vessel but prior to end-use application.
  - Suitable backflow protection will be required prior to the addition of chemical.

## **WATER RECLAIMED FROM HEAT EXCHANGER PROCESSES FOR NON-POTABLE USE**

Water may be reclaimed from plate heat exchangers on dairy farms and used for parlor floor wash down, manure pan flushing, holding area flushing, cattle watering and other non-potable uses without further testing. The outlet of the heat exchanger must be protected from backflow and must not reconnect with the potable water distribution system.

## **Bacteriological Standards for Private Water Supplies, Recirculated Water, and Reclaimed Water**

**Application:** To private water, recirculated cooling water, reclaimed water in dairy farms.  
Frequency: Initially, after repair, modification or disinfection of a private water supply of dairy farms and every 2 years thereafter; and initially, following repair, modification or disinfection of recirculated cooling water and reclaimed water on dairy farms and semiannually thereafter.

**Criteria:**

- A MPN (Most Probable Number of coliform organisms) of less than 1.1 per 100 ml, when ten replicate tubes containing 10 ml, or when five replicate tubes containing 20 ml, are tested using the multiple tube fermentation technique.

OR

- A MPN (Most Probable Number of coliform organisms) of less than 1 per 100 ml by the membrane filter technique,

OR

- A MPN (Most Probable Number of coliform organisms) of less than 1.1 per 100 ml when using a MMO-MUG technique. Note: The MMO-MUG technique is not acceptable for recirculated cooling water).

**Apparatus, Method, and Procedure:** Tests performed shall conform to the current edition of Standard Methods for the Examination of Water and Wastewater or with FDA approved, EPA promulgated methods for the examination of water and wastewater.



## **WISCONSIN REQUIREMENTS FOR LOCATING AIR INJECTORS**

Wisconsin Department of Agriculture  
Trade & Consumer Protection  
Division of Food Safety

The location of any air injector(s) must be listed on the pipeline plan submitted for review. All air injectors used for milk handling systems shall be in compliance with the following requirements.

- 1) Air injectors shall be installed in the milkhouse or an approved clean-in-place parlor.
  - The installation of air injectors in a milking barn is not allowed.
  - Air injectors installed in the milking parlor shall be equipped with an acceptable filter.
- 2) Air injectors installed on a milk-line shall meet sanitary construction standards for product contact surfaces or shall be removed from the milk-line during milking. If the Air injectors are removed during milking:
  - Sanitary caps shall be installed on both the injector and pipeline ports during milking.
  - The caps shall be cleaned and stored in the milkhouse when not in use.
- 3) Air injectors shall be close-coupled to the milk-line.
  - The distance between the air injector valve seat and the side-wall of the milk-line should not exceed two times the diameter of the injector mounting port or 5 inches, whichever is less.
- 4) Air injectors that are not closed coupled to the milk-line may require a separate wash supply line or jumper hose to assist in cleaning the stand pipe or may require manual cleaning.
  - All supply lines or jumper hoses shall be physically separated from the milk-line during milking.
  - Any openings in the milk-line shall be properly protected using clean sanitary caps.
  - The jumper hoses or sanitary caps shall be cleaned and stored in the milkhouse when not in use.

If you have any questions please contact your area Food Safety Consultant.



# WISCONSIN MILK HOUSE CONSTRUCTION REQUIREMENTS

Ref: Chapter ATCP 60, Wisconsin Administrative Code

1. Floors shall be of concrete or other equally impervious materials and be sloped for proper drainage to a floor drain ( $\frac{1}{4}$  inch per foot slope is recommended).
2. Floor drains shall not be under the bulk tank and shall be readily accessible. Floor drains shall be trapped if connected to a sanitary sewer system.
3. Milkhouse drain and CIP pre-rinse water must be piped into a waste handling system and may not run through gutters in the barn or parlor areas. Properly treated wash and rinse waters from CIP systems may be used for floor rinsing of parlors. Please contact the Department for more information about the use of reclaimed water on farms.
4. Waste from toilets and showers must be disposed of in a sanitary sewer system or by other methods that comply with ATCP 60.14(6).
5. Plumbing in the milk house should meet the requirements of the state Plumbing Code. Cleaning solutions should be discharged directly into the waste system and not across concrete floors. There shall be no cross-connections or submerged inlets.
6. All milk house doors shall be self closing and tight fitting. If the milk house opens directly into the barn, the door shall be solid. Screen doors on outside openings shall open outward.
7. Adequate ventilation shall be provided to prevent excessive odors and visible condensation on any milkhouse surfaces. Ventilators shall not be located directly above bulk tank openings. Windows shall be effectively screened. Air supplied to the milkhouse must be from outdoors or from other rooms that are clean and free of odors. Vents located between the milkhouse and the parlor, barn, or cattle housing areas shall be provided with a fan that exhausts the milkhouse air and vent louvers that close tightly after the fan stops. Forced air heating systems shall not blow air from milking or animal housing areas into the milkhouse.
8. There shall be at least 30 foot-candles of illumination in all working areas of the milkhouse. Artificial lights located over a bulk tank shall be shatterproof, or effectively shielded to protect milk from contamination from broken glass.
9. Adequate clearance shall be maintained on the top along the sides of the bulk tank. Clearances of 24 inches on the top and milk outlet side and 18 inches on all other sides are recommended.
10. A hose port is required if a bulk tank is used and shall be installed in an outside wall at least six inches above the floor. A paved surface of concrete or other cleanable material shall be installed adjacent to the outside wall under the hose port. The minimum size of the paved surface is 4 ft. by 4 ft.
11. The milkhouse walls and ceiling shall be constructed and finished so that they are impervious to water, light colored and easily washable.
12. The milkhouse shall be large enough to accommodate all necessary equipment.
13. A milkhouse shall be equipped with a fixed handwashing facility which is separate from the wash and rinse vat. The handwashing facility shall be served by potable hot and cold running water from a faucet or faucets located directly over the facility. Water shall enter and leave the handwashing facility by means which preclude splash. Single service sanitary towels and soap shall be available at all times for use at the handwashing facility. A handwashing facility may be located in a room immediately adjacent to the milkhouse, provided that it is readily accessible from the milkhouse.
14. DNR administrative code NR 812 specifies safe distances between the well and possible sources of contamination. NR 812 applies to all private water wells in Wisconsin including dairy farms.
15. A two compartment wash vat is required. It shall be supplied with potable hot and cold running water from a faucet located directly over the wash vats. A CIP wash vat can be used to meet the requirement for one of these vats as long as it has no brackets that would restrict its use. The milking units must be stored properly while the CIP vat is being used for the manual cleaning of equipment.
16. Water heating capacity shall be adequate for all milkhouse operations. The producer or installer shall determine the water heating capacity needed. Guidance for sizing water heating systems can be obtained from The Dairy Practices Council publication number 58; "Guidelines For Sizing Dairy Farm Water Heater Systems"<sup>1</sup> or from a milking equipment installer.

<sup>1</sup> Order From: The Dairy Practices Council, 51 E. Front Street, Suite 2, Keyport, NJ 07735, Telephone/Fax: (732) 203-1947 or online at [www.dairyipc.org](http://www.dairyipc.org).

---

WISCONSIN BULK TANK INSTALLATION REQUIREMENTS  
ATCP 60 Excerpts

---

**ATCP 60.10 Milking and milk handling systems.**

**(6) REVIEW OF PLANS.** (a) Before installing, reconstructing or extensively altering a bulk tank, or a milking or milk handling system, the installer shall submit plans to the department for review...

**(7) CERTIFICATION OF COMPLIANCE BY INSTALLER.** A person who installs, reconstructs or extensively alters a milking or milk handling system shall certify to the owner of the system that the system has been installed or modified in compliance with this section, and in compliance with the plans filed with the department under sub. (6) (a). A signed written statement certifying compliance shall be provided to the owner immediately after the system is installed or modified.

**ATCP 60.11 Bulk tanks and bulk transport containers.**

**(1) BULK TANK LOCATION.** If a bulk tank is used to receive, cool or store milk on a dairy farm, the bulk tank shall be installed in the milkhouse. A bulk tank may be installed so that a portion of the bulk tank protrudes through the wall of a milkhouse, provided that all bulk tank openings are located inside the milkhouse. Agitator seals, other than weatherproof agitator seals approved in writing by the department, shall be located inside the milkhouse. Adequate clearance shall be maintained on the top and all sides of a bulk tank to permit effective cleaning, sanitizing and maintenance of the bulk tank. No bulk tank opening may be located directly under a ventilator. No bulk tank may be located directly over a floor drain.

**Note:** Clearances of at least 24 inches on the top and the milk outlet side of the bulk tank, and 18 inches on all other sides of the bulk tank, are adequate to comply with this subsection. No clearance is required for that portion of a bulk tank which protrudes through the wall of a milkhouse.

**(2) BULK TANK CONSTRUCTION.** (a) The lining and milk contact surfaces of a bulk tank shall be constructed of stainless steel or other materials which are equally smooth, nontoxic, stable, non-absorbent, corrosion resistant, and capable of withstanding cleaning and sanitizing treatment. Milk contact surfaces shall be readily accessible for inspection.

(b) A bulk tank shall be self-draining. Openings shall be equipped with self-draining covers. Openings and

covers shall be constructed and installed to prevent drainage into milk, or onto milk contact surfaces.

(c) A bulk tank shall be equipped with an accurate thermometer which indicates milk temperatures. The thermometer shall have a minimum range of 32° F. (0° C.) to 80° F. (27° C.). Bulk tanks manufactured after January 1, 2000, shall be equipped with a recording thermometer. A milk producer shall retain milk temperature records for at least 90 days, and shall make the records available to the department for inspection and copying upon request.

(d) A bulk tank with a capacity of less than 1,500 gallons shall be equipped with a mechanical agitator which will ensure homogeneity of all milk contained in the bulk tank within 5 minutes after the agitator begins operating. A bulk tank with a capacity of 1,500 gallons or more shall be equipped with an agitator which will ensure homogeneity of all milk contained in the bulk tank within 10 minutes after the agitator begins operating.

(e) A bulk tank which is designed to be cleaned in place by the mechanical circulation of cleaning, rinsing and sanitizing solutions onto interior milk contact surfaces shall be designed and constructed so that cleaning, rinsing and sanitizing solutions cannot enter the bulk tank while it contains milk.

**Note:** Bulk tanks manufactured in compliance with the "3-A Sanitary Standards for Farm Milk Cooling and Holding Tanks" meet the sanitary design and construction requirements of this subsection. The "3-A Standards" are published jointly by the International Association for Food Protection, Inc., and the Food and Drug Administration, Public Health Service, U.S. Department of Health and Human Services. Copies of the "3-A Standards" as amended effective November 20, 1993, are on file with the department, the secretary of state and the reviser of statutes. Copies may be obtained from the International Association for Food Protection, Inc., 6200 Aurora Avenue, Suite 200W, Des Moines, IA, 50322-2863; Telephone 1-800-369-2863.

**(3) BULK TANK COOLING CAPACITY.** A bulk milk tank shall be capable of cooling all milk placed in the tank to a temperature of 50° F. (7° C.) within one hour after the milk is placed in the tank. If uncooled milk from subsequent milkings is added to cooled milk in the bulk tank, the bulk tank shall be capable of maintaining the blend temperature at or below 50° F. (10° C.), and reducing the blend temperature to 45° F. (7° C.) within one hour.



## Requirements For Mini-Milkhouse/Pumphouse

A question regarding this practice was again brought up concerning the construction. Following is clarification of the practice already being allowed.

### **Mini Milkhouse/Pumphouse**

An area outside of the milkhouse used to house the receiver jar and milk pump.

Purpose: To allow the installation of a pipeline system in milking facilities where due to the existing construction and location of the milkhouse it would be impossible to provide the proper slope and placement of the receiver jar in the milkhouse.

What equipment may be located in an area designated as a pumphouse only (no milkhouse washing facilities)

1. Receiver Jar
2. Milk Pump
3. Milk Line Drain
4. Moisture Trap

### Construction

1. Provide adequate lighting - 30ft candles of illumination.
2. Walls, floor and ceiling must comply with milkhouse standards.
3. A trapped floor drain shall be provided.
4. Adequate room shall be provided to service equipment.
5. Access may be accomplished from the barn.
6. All access points into the pumphouse must be dust tight.
7. Must be maintained, clean and accessible for inspection.
8. Hot and cold running water shall be provided.



## WISCONSIN MILKING PARLOR CONSTRUCTION STANDARDS

Wisconsin Department of Agriculture,  
Trade & Consumer Protection  
Division of Food Safety

**This standard applies to milking parlors where CIP milking equipment is cleaned and stored.**

1. Floor and Gutter Construction:

a. Floors and gutters shall be constructed of concrete or other materials that are equally impervious and easy to clean. Floors and gutters shall be sloped at least one inch per 10 feet to the drain. Gutter covers, if installed shall be made of impervious material and be removable for cleaning.

b. A watertight sump with pump may be used to elevate the liquid in the operators pit into the gutter.

2. Wall and Ceiling Construction:

a. Walls and ceilings shall be constructed and maintained so that they may be kept clean. Wall and ceiling finishes shall be light colored and easy to clean.

b. Doorways to and from the milking parlor shall be provided with tight-fitting solid doors. These doors shall be closed when equipment is being cleaned or stored. Strip curtains are not allowed as a replacement for solid doors. Openings shall be protected against entry of insects, rodents and other pests.

c. Windows should be installed flush with the inside parlor walls or the sill should be sloped to drain completely.

d. Open-air parlor facilities are designed for non-confined animal housing systems (rotational grazing). These facilities are exempt from CIP parlor wall, door and window standards. All open-air parlors require a formal variance issued by the department. Contact the area Food Safety Consultant for additional information.

3. Lighting:

a. Natural or artificial lighting shall be provided in parlors to ensure adequate illumination for daytime and nighttime milking operations.

b. There shall be at least 10 foot candles of illumination in all working areas and at least 30 foot candles of illumination in all areas of the milking parlor where C-I-P milking equipment is cleaned, sanitized and stored.

4. Ventilation:

Ventilation shall be adequate to prevent visible condensation on walls and ceiling, and to prevent excessive odors. Heating, ventilating and air conditioning systems shall be designed so that air from the parlor, animal housing areas and toilet room may not enter the milk room.

5. Milking handling equipment:

a. All milk handling equipment installed shall comply with 3A Accepted Practice 606-05 and ASAE Standard S518.2.

b. Before installing a milk handling system, the installer shall submit plans to the department for review.

c. **New** milk handling systems or equipment shall not be sold until specifications or prototype equipment are **first** reviewed by the department.

d. Butterfly valves shall be of sanitary design and construction. They shall be easy to access and disassemble. Butterfly valves shall be disassembled and cleaned after each milking.

e. Air under pressure in contact with milk shall comply with 3A Accepted Practice 604-04. Areas of primary concern are the use of a disposable media filter and the sanitary check valve located at the point of application. This valve requires hand cleaning after each use.

f. Milk handling systems shall be effectively separated from the cleaning make-up vats or the CIP solution lines during milking to avoid possible contamination.

g. C-I-P milking equipment, if cleaned, sanitized or stored in the milking parlor, shall be designed, installed, handled and stored so that milk contact surfaces are protected from contamination at all times.

h. The installation of the receiver group in a pit is not recommended unless an adequate means is provided to preclude cross-contamination of the milking system with the floor drains located within the pit.

i. Milk lines, when installed embedded in concrete should be sleeved with oversized PVC piping to allow for line expansion and inspection.

6. Water systems:

a. Wells used to supply water shall comply with chapter NR 812, Wisconsin Administrative Code.

b. All plumbing shall comply with chapter IHLR 82, Wis. Adm. Code.

c. Water discharged from milk pre-coolers may be used for milkhouse and milking parlor operations, watering livestock and holding area wash down.

- The pre-cooler water reclaim system shall meet the requirements listed in department guideline F-Fd-36, "*Wisconsin Dairy Farm Milk Pre-Cooler Requirements*".
- Reclaimed water storage tanks shall not be cross connected to the potable water system.
- Outlet lines from the plate cooler shall not be cross connected to the potable water system.

d. An air gap shall be maintained between every potable water outlet and the flood rim of the vessel that it supplies, and between the potable water outlet and any source of potential contamination, unless an alternate method of protection is provided.

e. If cows are cleaned in a milking parlor prep stall prior to milking, rather than being manually cleaned at the milking stations, hot water under pressure shall be supplied to the prep stall and used for cleaning purposes. There shall be an adequate supply of hot water so that all cows processed through the prep stall may be fully cleaned without impairing the availability of hot water for other milking parlor or milkhouse operations.

7. Wastewater Handling:

a. Wastewater containing milky pre-rinse from pipelines and bulk tanks should be used for animal feed or deposited in the manure handling system.

b. Detergent wash, acid rinse, and sanitizing solutions (graywater) may be collected and reused for milking parlor floor, wall and holding area washdown.

c. Wastewater generated during water softener discharge may be used for milkhouse, milking parlor and holding area washdown.

d. Wastewater collected from floor drains should not be reused for milking parlor floor, wall and holding area washdown.

e. When a liquid tight holding tank is installed for wastewater it should be provided with a manhole opening sufficient for inspection and cleaning as necessary.

f. Manure and liquid wastes from milking parlor operations shall be drained and removed from the parlor in a sanitary manner after each milking, so that there are no solid or liquid waste accumulations in the milking parlor.

g. Sewage from toilets and showers shall be disposed of in a septic system. Sewage shall not be disposed of in the manure handling system. The use of chemical toilets, pit privies, and incinerator toilets meet the intent of this section



## **WISCONSIN DIRECT TANKER SHIPPING REQUIREMENTS**

1) The facility and equipment must comply with the applicable sections of ATCP 60 (Dairy Farm Code), applicable sections of the 3A Standards and this policy.

2) A written plan must be submitted to the Department prior to the commencement of this type of operation. This plan is to be submitted using the following:

Application For Milk Handling Equipment Installation (F-Fd-31)

Direct Tanker Milk Shipping Supplemental Application (F-Fd-258)

A detailed drawing of the milking facility and equipment layout

Please be sure all applicable information is provided on the application form. In addition the plan must also address the following concerns:

### **FARM/PRODUCER PROCEDURES**

- a) Frequency of delivery.
- b) Maintenance/testing of the cooling system.
- c) Method of attaching the hose, the location of such attachment, and the method of sanitizing these connections.
- d) CIP procedures, (with special attention to how the hose will be washed and stored.)
- e) Proper equipment to monitor temperatures of the milk.

### **PLANT PROCEDURES**

- a) Agitation of the milk.
- b) Sampling procedures and location.
- c) Drug testing procedures.

### **TANKER/FACILITY REQUIREMENTS:**

#### **TANKER:**

- a) Must meet applicable 3 A Standards for construction and be licensed as a Wisconsin Bulk Milk Tanker.
- b) The tanker outlet valve must be close coupled.
- c) Unless the outlet valve is located in a pump/hose cabinet, it shall be protected with an effective dust cover.
- d) The tanker access port cover must be able to be sealed so it can be made tamper detectable.

#### **FACILITY:**

- a) The surface on which the tanker is parked must be constructed of concrete or other equally impervious material. It must be sloped to provide adequate drainage and be maintained in good clean condition.
- b) All permanent pipelines shall terminate in the milkhouse.
- c) A recording thermometer shall be located downstream of the milk cooling device. The recording device probe shall be installed in a sanitary well in this pipeline. All thermometers and recorders shall comply with the 3 A Standard 13-09, Sections J1 and J2.
- d) An acceptable in-line milk sampling device may be installed on the pipeline system. This device can only be used by the producer to screen their milk for drug residues. It is **not** to be used for any official drug screening or quality tests.
- e) Milk must be cooled to 45 degrees F or colder prior to it entering the tanker. The method of cooling must be reviewed by the Department to determine if the equipment used meets the construction guidelines listed in the 3A Standards and the cooling requirements covered in ATCP 60.12(4).
- f) If a closed loop cooling system is used, the cooling medium must be sampled every six months and be found free of coliform bacteria by a certified lab. A copy of these test results shall be posted in the milkhouse and on file at the dairy plant at which the producer is assigned. All cooling medium must be of an approved food grade material and the system must be properly designed and operated to prevent contamination. If water is used to cool the milk supply it must comply with ATCP 60.08.
- g) A cooling tank may be used in lieu of a plate or tube cooler/chiller. If a cooling tank is used the temperature recording device must be placed on the tank. The tank shall be cleaned when emptied and in no case shall it be cleaned less than once every 48 hours.

**FARM PROCEDURES:**

**a) Continuous milking operations (where the tanker is filled during one continuous milking period and then it is hauled to the dairy):** This procedure would allow the tanker to be located away from the milkhouse. The tanker must have the outlet valve and hose located in a sanitary protective type cabinet. The one-time hose connection would be made in the milkhouse. All other routine sanitation procedures must be followed.

**b) Multiple milkings into a tanker:** This practice requires that the tanker outlet valve be located in the milkhouse so it can be effectively washed and sanitize. This can be done by providing a protected opening into the milkhouse where the rear of the tanker backs up to. This tanker/milkhouse connection must be tight to prevent the entrance of insects and other pests. Other methods will be reviewed and accepted if they are found to meet the intent of this section.

**c)** The tanker outlet valve shall be sanitized prior to connecting the milk transfer line.

**d)** All pipeline and hose caps shall be stored in the milkhouse during milking operations.

**e)** The milk transfer hose shall be of a sanitary design. If this hose is a part of the milkhouse equipment, (not washed with the tanker), it must be stored in a self-draining position with the ends protected from contamination. The hose shall be disconnected from the tanker before it is washed and sanitized with the rest of the milking system on the farm.

**f)** There is no limit to the number of times milk can be added to the tanker as long as the outlet valve and hose connections are washed and sanitized between milkings. The Department would require that the tanker be on the farm for no longer than 48 hours from the time the milk was first placed in it.

**DAIRY PLANT PROCEDURES:**

**a) TANKER SEAL:** The Department requires that all tankers be washed and sanitized in an approved facility and requests that a seal be applied to the access port cover, (to reduce the chance of contamination), before it leaves the wash facility to the farm. All other requirements regarding the construction of the equipment, the sampling procedures, and the proper cleaning methods covered by the Department rules and regulations must be followed.

**b) AGITATION:** An adequate method of agitation is needed to assure that the product has achieved homogeneity. The Department requests that a standard procedure be established for each producer who is direct tanker shipping to your facility that guarantees that the milk sample truly represents the entire load. The Department references "Standard Methods" for appropriate methods of agitation. We would request that a copy of these test procedures be made available upon request. The method of agitation must be reviewed by the Department prior to its implementation.

**c) SAMPLING:** The product in the tanker should be sampled by a licensed bulk weigher and sampler at the dairy plant.

1) All tanker loads must be screened for drug residue upon delivery to the dairy plant.

2) A sample for producer milk quality must be collected after the milk has been properly agitated. Only an approved sample cock properly located or a sanitary dipper type sample will be accepted. An automatic drip sampler is not considered to be an acceptable device for obtaining this sample nor is a sample collected from the tanker outlet valve.

3) If the tanker originates from a farm with a totally enclosed and approved truck bay, the official quality sample could be taken on the farm, but only if the milk was properly agitated and collected by a licensed weigher and sampler.

**d)** The dairy plant shall record the temperature of each delivery of milk.

**e)** A duplicate copy of the weight collection record shall be returned to the farm and be posted in the milkhouse.



## ADDITIONAL CONSIDERATIONS FOR DIRECT TANKER SHIPPING

### PLAN SUBMITTAL:

Since these types of operations involve a number of important issues we are requesting the installer of the equipment to contact the Food Safety Consultant assigned to the area in which the producer is located. Communications between the producer, equipment installer, dairy plant field representative, and the food safety consultant are crucial in making sure that these types of operations are in compliance with all applicable rules and standards.

We are requesting that in addition to the basic pipeline plan being submitted to the Department, a more detailed drawing of the facility and equipment should be included. Items of importance are as follows:

- 1) The location and type of temperature recorder
- 2) The type of materials used and the design of how the tanker will be connected to the milkhouse
- 3) The design of the level sensor device on the tanker including how it might affect the weather cover over the manhole opening.
- 4) The type of milk cooling device that will be used. List the type of coolant such as glycol etc.. Please explain how the coolant is to be sampled such as using a sanitary dipper or will a sample faucet be provided, or other possible options.

**An application has been developed that will assist you in providing all of the necessary information to the Department for processing this type of plan submittal. Please use this application and attach it to the plan before submitting it for review.**

### EQUIPMENT DESIGN:

#### TANKER:

1) The Department recommends that the level sensor be located under the weather cover on the tank manhole opening. This is to assure that it can be easily accessed for inspection and cleaning. Because the weather cover must be sealed closed after washing, the tanker level sensor cord needs to be in place with the end protruding outside before leaving the wash facility. This will need to be connected to some type of alarm system at the dairy farm. The cord should be able to be run under the weather cover. No holes should be made in the weather cover unless they can be effectively sealed in a sanitary manor. Other methods would be considered and accepted if they can be shown they meet the intent of this policy.

2) If the tanker is modified to provide air or mechanical agitation of the milk these devices must be installed to meet the applicable 3A Standards.

3) If the exterior of the tanker is to be modified so it can fit tight to the milkhouse opening we request that these changes meet the 3 A Standards for proper design and finish.

4) There has been some concerns raised about older style tankers which may not be as insulated as the newer models. This may cause the initial milking into the tanker to be too warm or for the load to warm up too much prior to it's delivery to the dairy. The tankers may need to receive a cold water sanitizer rinse to lower the tank temperature before leaving the dairy plant.

### **MILK HANDLING EQUIPMENT:**

1) Please reference the Department's policy on the installation of milk pre-coolers to be sure that all of the concerns in that document are addressed.

2) Consider the following when installing the temperature recording device:

a) The Department recommends that the recorders also have a digital display of the temperature or that an accurate dial type thermometer be installed on the system because the pen recording is small and difficult to see from a distance. It would be easier to detect cooling problems if the temperature reading was more visible.

b) The temperature recording device must comply to the 3A Standard # 13-09 J2. This standard requires the recording chart to have a span of not less than 50 degrees F and shall include a range of plus or minus 5 degrees F from the normal product temperatures being monitored. The charts shall be graduated in not more than 2 degree F graduations which are spaced no less than 1 mm apart. The charts must also be capable of recording temperatures up to 180 degrees F. The Department is also recommending that the chart make no more than one revolution every 48 hours. If strip chart type recorders are used the chart must move at least 1 inch every hour and may be used continuously for up to one month.

c) Some temperature recorders have the capability of setting off an alarm if the milk temperature rises too high during milking. Even though this is not a requirement it may be beneficial to catch this problem before the tanker of milk becomes too warm and must be hauled to the dairy immediately or risk losing the load due to spoilage.

d) The recording chart temperature probe must be sanitary in design and have no threads in the product contact zone. The Department recommends that the probe be installed in a sanitary well on the pipeline instead of it being in direct contact with the milk. This would allow the probe to be removed for testing even during times where there is milk in the system.

e) Currently the Department inspectors conduct accuracy checks of the bulk tank thermometers during routine farm inspections. If this check is to be made on these types of operations then an easy method to do so would be most beneficial. The recording thermometer probe could be taken out and placed in ice water, but that would be time consuming and difficult in many cases. One quick method would be to provide another small well in the pipeline near the recorder probe. This well should extend into the middle of the pipeline and the inside diameter to be not much larger than the stem of an average pocket type thermometer. This would allow for the insertion of the test thermometer during production to obtain a reasonable check of the accuracy of the recording device. Other methods could be used to facilitate this procedure.

3) If hoses are used in the milkhouse to make the connection from the pipeline to the tanker outlet valve the Department recommends that they be of the seamless sanitary type and be cleaned in place with the rest of the pipeline system.

### **FARM PROCEDURES:**

Some studies have shown that bacteria counts begin to increase when the duration of the milking time exceeds 8 hours. This should be considered when establishing your milking and equipment clean-up procedures.

### **FARM FACILITIES:**

In most cases the tanker will need to be backed up tight to the milkhouse to comply with the standards. The junction between the tanker and the milkhouse needs to be tight. Please consider the following when designing this connection:

1) The material used between the tanker and building must be washable and non-absorbent.

2) The opening needs to be large enough to be able to access the tanker outlet valve for inspection and cleaning purposes. It must also be properly finished off to facilitate cleaning.

3) Since there may be milk residues coming from the tanker outlet valve the Department recommends that some type of sanitary drip pan be used to convey the waste into the milkhouse. This would prevent the milk from pooling on the sill area or running down the outside wall.

#### **DAIRY PLANT PROCEDURES:**

##### **SAMPLING PROCEDURES:**

1) The Department would suggest that the licensed individual who is sampling milk from the tanker not be the producer of the milk or an agent acting on the producer's behalf. This could create potential conflicts in the future.

2) The point of sale of a tanker of milk from a **single farm** is when the dairy plant or an agent of the dairy plant has accepted it. If a producer or an agent of the producer delivers a load of milk to the dairy plant and it is confirmed positive for drug residue, the load of milk does not have to be reported to the Department. It does have to be properly disposed of. This policy may not agree with that of other agencies which may regulate your dairy plant as well. You should check with those agencies before establishing your policy on this matter.

3) Proper agitation of the milk is crucial for obtaining an accurate sample. A number of methods have been suggested which include air or mechanical agitation in the tanker, pump circulation systems, or transferring the milk to a storage vessel at the dairy plant. All of these methods could work, but may create concerns if not properly set up. The Department strongly recommends that the details of the method that is selected be discussed with the Food Safety Consultant prior to its implementation.

##### **PRODUCER MILK SALES TO DAIRY PLANTS:**

The **Food Division** of The Department of Agriculture T&CP does not set policy as to the sale and payment for milk delivered to a dairy plant. This is regulated under the Trade and Consumer Protection Division. Please reference ATCP Chapter 100, (Dairy Plant Payments To Milk Producers: Security), for information regarding this subject.

##### **WEIGHING AND MEASURING DEVICES:**

The **Food Division** of The Department of Agriculture T&CP does not set policy regarding the accuracy of the devices used to weigh and measure milk. The Department recommends that ATCP Chapter 92,(Weighing and Measuring Devices), and the NIST Handbook 44 be referenced for information regarding these devices. It is however important that a method of weighing the milk for payment be agreed upon by the producer and dairy plant before shipping begins. It may also be a good idea to put this agreement in writing to avoid possible conflicts in the future.



Wisconsin Dept. of Agriculture, Trade & Consumer Protection  
 Division of Food Safety 608-224-4700

## DIRECT TANKER MILK SHIPPING SUPPLEMENTAL APPLICATION

NAME		
DBA(FARM NAME)		
MAILING ADDRESS		
CITY	STATE	ZIP
COUNTY NAME & #	TOWNSHIP NAME & #	SECTION
PHONE NUMBER		
PRODUCER'S SIGNATURE		DATE

This form shall be completed and submitted with the Application for Milk Handling Equipment Installation (f-fd-31) accompanied by the required plan review fee.

ATCP 60.10(6), Wisconsin Administrative Code requires the installer to submit plans prior to the installation of any milk handling system. Coordinate the completion of this supplemental application with both the dairy producer and dairy plant in order to obtain accurate information. Refer to the department's "Direct Tanker Shipping from the Farm Requirements" and "Direct Tanker Shipping from the Farm - Additional Considerations" documents for guidance.

- 1) Describe the material type, size and method of drainage for the surface where the tanker(s) will be parked outside of the milking facility.
  
- 2) Describe the method for providing a sanitary connection between the tanker(s) and the milkhouse or other sanitary room. Include details on the size and materials used on these openings, the type of doors used for the openings, and the method of catching or eliminating any liquid waste when the milk hose is connected and disconnected from the tanker outlet valve.
  
- 3) Describe the type of tanker(s) that will be used on the farm, (over the road or hose cabinet type tankers). Where will the tanker(s) be washed? Who owns the tanker(s)? Provide the Bulk Milk Tanker License number for each tanker. Tankers must meet the construction standards listed in the 3A Guidelines. Proper tank insulation is important for maintaining acceptable milk temperatures.

- 4) Describe any modifications to the tanker(s), i.e., the construction of a housing around the outlet valve so it fits tight to the milkhouse, the location and installation method of the level sensing device on the tank and how the outer weather cover will be sealed. Document what will occur when the level sensor indicates a high milk level.
  
- 5) Describe the milk cooling system that will be used, include the location and the type of cooling media(s) used. Indicate who will be responsible for collecting a sample from the recirculated cooling system every 6 months and ensure the test results are posted on the farm and at the dairy plant. Provide data that indicates the estimated milk temperature after the milk cooling system.
  
- 6) Provide the manufacturer, temperature range, accuracy and location of the temperature recording device. (The submission of a blank recording chart is recommended.) . Describe the method of attachment for the temperature recording probe to the pipeline and provide a method to conduct accuracy checks of the temperature recording device. **Note: The temperature recorder must comply with specific standards. Please refer to items 2 b & c on page 2 of the Additional Considerations Document.** Please indicate if the recorder will have a high temperature alarm feature, (not required).
  
- 7) Describe the milking procedures on the farm, to include how long the tanker will remain on the farm and the number of milkings placed in the tanker before shipment to the dairy plant.
  
- 8) Describe the wash procedures of the equipment on the farm, to include the frequency of the cleaning and sanitizing cycles and how the tanker valve and any associated appurtenances will be washed, sanitized and stored.

Define the "Point of Sale" of the milk, (either at the farm or at the dairy plant). The "Point of Sale" is defined as the point at which the dairy plant takes ownership and control of the milk.

- 9) Describe the method of weighing and sampling of the bulk milk tanker. The method provided shall include a proper method of agitation, weighing, and sampling. Provide the method, duration and location of the agitation system used and include the method of cleaning and sanitizing the agitator. Identify the sampling technique and location where the tanker will be sampled. (**Note:** The milk must be sampled by a licensed weigher and sampler.) Identify the accurate weighing method to be utilized on the milk tanker, acceptable systems include; “a certified truck scale” or “a certified flow meter system”.
- 11) Describe briefly the pipeline system in the milkhouse. Include items such as jumper hoses (must be seamless type), how the hoses are supported for proper drainage, check valves, milk filter arrangement (one or more filters used), etc. Please indicate the location of these devices in your pipeline drawing submitted with this application.
- 12) Describe the method of collection and analysis of the official drug residue sample for the tanker load.

If you have any question please contact the Food Safety Consultant assigned to your area.

# QUESTIONS & ANSWERS

## DATCP INSTALLER MEETINGS

March 1997

1. How do you determine if a producer is a careful or typical operator as described in ASAE Standard S518.2, Annex C? **ANSWER:** This is a decision to be made between the producer and installer. A caution will be added to the plan review letter if the sizing for careful operator option is chosen.
2. Does production enter into units per slope? Shouldn't charts be based on DHIA standards? **ANSWER:** The formula was designed for the "fastest- milking 5% of cows (see ASAE Standard S518.2, Annex C). This should be adequate in most cases but the only way to verify system sizing is performance testing.
3. Are the requirements for a plate cooler and an in- line tube cooler the same? **ANSWER:** See the guidelines for milk precoolers.
4. Must cold air returns be located outside? **ANSWER:** The air system for the milkhouse and CIP parlor must be separate from areas where animals congregate or are housed.
5. Can waste water be disposed of outside the milk house or milking parlor on the ground? **ANSWER:** Water from milkhouse operations (not from toilet or shower) may be disposed of above ground if it does not pool or cause odorous or unsanitary conditions. (Check local ordinances or zoning requirements that may prohibit this practice).
6. Can cow platform rinse water be stored in an intermediate tank and be used to rinse the holding area? **ANSWER:** Yes, if the water is of adequate quality for the intended use.
7. What does "modification" on the application form mean? **ANSWER:** Modification means that changes are being made to an existing system.
8. New app form - Do you need to know the type of coolant? **ANSWER:** We have provided a space on the new form to specify what type of is used in **recirculated systems only**. The coolant will be water or glycol.
9. What is a recirculated cooling system? **ANSWER:** That describes a system that reuses coolant as opposed to using the coolant once.
10. Have the pipeline plan review fees gone up? **ANSWER:** No.
11. Does installing take off units in a stanchion barn require an application? **ANSWER:** Yes, if the sensor is cleaned in place or if it increases the vacuum demand.
12. Can you run a gutter through a parlor where the units are removed to the milkhouse for cleaning? **ANSWER:** Yes.
13. Is a wash manifold required? **ANSWER:** No, if the cleaning inlets are of sanitary design and easy to disassemble. (Note: This was changed in 1999 and a wash manifold is now required on all new systems.)

14. Are plans required for replacing vacuum pump if the new pump doesn't meet standards? Can you replace existing vacuum pump with same or larger capacity without submitting a plan? Does a new vacuum pump require an application? **ANSWER:** See guideline F-Fd-39, "*Wisconsin Requirements For Milking Equipment Plans*" in this manual. Replacement pumps must be sized according to the current standard. If the pump is the same capacity or greater capacity than the original no plan is required. Verification by performance testing is recommended.
15. Is there a portable pasture parlor approved in Wisconsin? **ANSWER:** No.
16. Could you use a mobile bulk tank? **ANSWER:** Only if a bulk tank was modified to protect milk outside the milkhous environment and was loaded and unloaded in an enclosed room.
17. What are the regulations on milk hose inlet size? **ANSWER:** There is no specification in the regulations for milk hose inlet size.
18. Who is liable if a pipeline system is installed sized for a careful operator but fails due to operator carelessness? **ANSWER:** We are not qualified to give a legal opinion. We suggest that you contact an attorney.
19. Is the plan review letter sent certified? **ANSWER:** No.
20. Do the jetter lines have to have a physical break from the CIP system? **ANSWER:** Yes, they must be disconnected from the milk line during milking. They must also be protected from contamination during milking.
21. Can milky wastewater from the parlor be re-used to wash down the parlor or holding area? **ANSWER:** Water used to wash down the parlor or holding area must be of adequate quality for the intended use. The practice of reusing prerinse and floor drain water is a very bad animal health practice and we strongly discourage it.
22. Is a back flow preventer required for plate coolers? **ANSWER:** See guideline F-Fd-36, "*Wisconsin Dairy Farm Milk Pre-Cooler Requirements*" in this manual.
23. Can water used to cool a compressor be saved for potable use? **ANSWER:** Yes, in properly designed equipment. This would mean that the water would be enclosed and would only contact approved materials (similar to a water piping system). Seal water from water sealed vacuum pumps cannot be reclaimed as potable. See guideline F-Fd-36, "*Wisconsin Dairy Farm Milk Pre-Cooler Requirements*" in this manual.
24. Where do you need back flow prevention? **ANSWER:** Anywhere that chemicals and other types of contamination could siphon back into the potable water system.
25. How can we sign the application after installation if we don't get a copy? **ANSWER:** The producer gets a copy you can sign. We will see that the installer also gets a copy of the application. The installer can also use his own form to confirm proper installation.
26. Who is required to sign the application? **ANSWER:** The installer, the producer, and the reviewer.
27. Can you convert part of a barn into a flat barn milking system with the remaining area converted to free stall housing? **ANSWER:** Yes, however any area open to the milking facility must meet milking barn construction and sanitary requirements. This will be very difficult to do.
28. Are plate coolers allowed to be installed in utility rooms? **ANSWER:** A plate cooler may be installed in any room meeting acceptable facility standards for CIP equipment.

29. Do you need to use a double bucket system when milking fresh or treated animals? **ANSWER:** The milking system must be designed and operated to prevent contamination of the milk with abnormal milk or drug residues.
30. Can part of a conventional barn be converted to a parlor and the existing barn cleaner be left in place under the parlor floor? **ANSWER:** Yes, if it runs under the concrete floor of the parlor or is located under sealed, tightly secured metal plating.
31. Can sump pit wastewater be conveyed through the barn cleaner gutter? **ANSWER:** The barn gutter is not designed to handle liquid waste. Our experience has been that the practice causes unclean barn or cow conditions.
32. Does every vacuum system require the 35 CFM for the reserve capacity? **ANSWER:** Yes. See ASAE Standard S518.2, Annex A.
33. Is an extra 35 CFM vacuum reserve required for each additional operator in a parlor? **ANSWER:** No, because the ASAE standards already factor in that all of the units would be used simultaneously.
34. Does the ASAE standard provide for enough vacuum for cleaning the system? **ANSWER:** If sized according to ASAE Standard S518.2, Annex A there should adequate vacuum for cleaning. This should be verified by performance testing as specified in ASAE Standard EP445.1.
35. Should veterinarians or installers be recommending that one of the vacuum pumps be shut off on pipeline systems based upon the reduced vacuum requirement in the new standard? **ANSWER:** Modifications to milking system design or operation should not be made without performing the calculation and testing based on ASAE Standards.
36. Can you reduce the vacuum pump output by installing a smaller drive pulley? **ANSWER:** Yes, if you perform the calculation and testing based on ASAE Standards.
37. Should we tell farmers that are using 3-4 units per slope on a 2" pipeline to reduce these numbers to meet the standard? **ANSWER:** Regulations do not require that existing systems be brought up the present standards unless modifications are being made. You always have the right to communicate your concerns to your customers.
38. Can 7 units be used on a 2" pipeline with 3 units on one side and 4 units on the other? **ANSWER:** See ASAE Standard S518.2, Annex C for proper number of units per slope for various line sizes and slopes.
39. Must equipment and hoses be completely dry after washing? **ANSWER:** Equipment must be installed so that it drains completely or is mechanically dried by the system. The normal clingage of moisture after draining is not a violation.
40. Do regulations prohibit feeding in a parlor where units are washed and stored? **ANSWER:** No. However we do not recommend it because the parlor may be in violation of the cleaning requirement.
41. Do regulations allow alternate sources of hot water? **ANSWER:** Yes. ATCP 60 requires the alternate source to be adequate.
42. Do regulations prohibit disposing of sewage (waste from toilets and showers) in manure pits? **ANSWER:** The FDA and DATCP prohibit that practice on dairy farms.
43. Can the short tygon hoses for washing take-off sensors be left in the barn during milking? **ANSWER:** Yes, as long as they are capped or plugged when they are not hooked to sensors.

44. How far can drains be located under the bulk tank? **ANSWER:** The purpose of the regulation is to keep the drain accessible for cleaning. If the drain is under a portion of the bulk tank that does not fit close to the floor and it is accessible for cleaning it may be accepted.
45. What are the standards for valves in contact with milk? **ANSWER:** The valve must be of sanitary construction and material as defined by 3-A Accepted Practice 606-05, Section D2.10.
46. What is the Department policy on double wash vats in the milkhouse? **ANSWER:** Double wash vats are still required. One of the two may be used for CIP as long as any obstructions can be easily removed.
47. What is the proper placement for back flow preventers? **ANSWER:** The back flow preventer must be placed to protect the potable water system (Human drinking and equipment cleaning and rinsing). It would be acceptable to place one back flow preventer between the milkhouse and barn as long as there is no potable use downstream of the preventer and all contamination sources are downstream of the preventer.
48. What is the acceptable device to install to protect a high-pressure wash pump? **ANSWER:** The acceptable devices are a low-pressure cutoff switch or a water supply tank with a non-siphoning water inlet.
49. Are the new speed controlled vacuum pumps acceptable as a replacement for the vacuum pump and regulator combination? **ANSWER:** They could be if the system passes all performance tests described in ASAE Standard EP445.1.



## Questions & Answers

### DATCP INSTALLER MEETINGS

December 1999

1. Why is the Department requiring a separate wash manifold on new pipelines? **ANSWER:** The inlet covers are up during cleaning and are milk contact surfaces. The undersides of the inlet covers do not get cleaned.
2. Are there any requirements concerning the location of a temperature chart recorder? **ANSWER:** There are no requirements concerning the location. It must be kept dry and accessible for inspection.
3. Could a data logger be used to record milk temperature? **ANSWER:** Yes. The recorder would have to be evaluated and approved by DATCP.
4. Could a second, detachable probe be used to check the calibrating of the temperature recorder? **ANSWER:** No. Each probe is different. The recorder is calibrated to the specific probe.
5. How long can an empty tanker be left at the farm after wash and sanitizing? **ANSWER:** As long as the seal is left on tanker. We recommend less than 48 hours.
6. Can milky pre rinse water be used for parlor washing? **ANSWER:** We recommend not using pre rinse for parlor wash.
7. How must wastewater from a shower be disposed of? **ANSWER:** Wastewater from a shower is sewage and must go to a sanitary sewer.
8. How must wastewater from a hand-wash sink be disposed of? **ANSWER:** All wastewater from a hand-wash sink in a toilet room must go to a sanitary sewer. If the hand-wash sink is in the milk house the water can go to the floor
9. Does a vertical wash tank need a lid? **ANSWER:** No.
10. Can milk flow through the CIP manifold? **ANSWER:** A CIP manifold must not have milk flowing through it in new or upgraded systems.
11. In what position must the CIP manifold be mounted? **ANSWER:** In any position which allows self-draining.
12. How can a potable water system be protected when using a pre-cooler? **ANSWER:** The best method is to use a tank that is filled using an inlet pipe with an air gap. A back flow preventer such as a Watts 9D can also be used. This item is under review by the FDA at this time. (See Guideline F-Fd-36, "*Wisconsin Dairy Farm Milk Pre-Cooler Requirements*" in this manual)
13. When converting a stanchion barn to a CIP parlor can a gutter be left in.? **ANSWER:** No. The gutter must be covered or eliminated.
14. What is required for compressed air used in an air blow? **ANSWER:** Sanitary air is required. There must be a dryer on the air line and a filter to remove contaminants. The final filter and check valve need to be located close to the point use. Please refer to 3-A Accepted Practices 604.04.
15. Do you need to be a certified welder to weld fittings on pipelines? **ANSWER:** No.

16. Why are only recommendations made on the number of units and slopes? **ANSWER:** The ASAE standard is flexible and ultimately relies on performance testing of the system.
17. Could materials other than stainless steel be used for wash vats or vertical CIP vats? **ANSWER:** Yes. Materials must be non-toxic, cleanable and durable for the intended use. We would need to evaluate the materials.
18. Why is the vacuum tested at the vacuum pump? **ANSWER:** The ASAE F 518 6.2 and 7 and the 3-A standards require vacuum measurement at this location.
19. Are there a required number of shipping docks on a direct ship farm? **ANSWER:** No. Usually there are three, one for a filled tanker, one for a filling tanker, and one for an empty tanker.
20. Could a tanker be sanitized on the farm? **ANSWER:** The tanker can only be sanitized where it is washed. The outlet valve can be sanitized at the farm.
21. Who is responsible for a dirty tanker? **ANSWER:** This is a legal issue and depends upon the agreement between the producer and the receiving plant. The plant that washes, sanitizes and seals the tanker is responsible for verifying that the tanker is clean. The producer is ultimately responsible for lower quality milk if the tanker is not clean.
22. How should a flow meter be set up to be used as a level sensor? **ANSWER:** The flow meter must be designed to not measure flow during the wash.
23. What are the requirements for a reclaimed water system? **ANSWER:** The requirements are in the 1997 PMO, Appendix D, section (6)VI. (The requirements are in the same section of the PMO, 2001 revision. Also see guideline F-Fd-36, "*Wisconsin Dairy Farm Milk Pre-Cooler Requirements*" in this manual.)
24. Is a poly tank acceptable for reclaimed water? **ANSWER:** Non-toxic plastic tanks are acceptable.
25. Is there a list of anti microbial agents that can be added to the propylene glycol in chiller systems? **ANSWER:** There is a list of approved sanitizers available from the DHFS, Division of Public Health. Other chemicals may be acceptable and need to be evaluated individually. Sanitizers must have an EPA approval and be used according to directions on the label.
26. Can an open-air parlor be converted to a conventional parlor? **ANSWER:** Yes. It becomes a regular parlor and must follow the regulations for conventional parlors. An open-air parlor is a seasonal operation and there are distance requirements from manure storage and cattle housing. Open-air parlors require written approval.
27. Are butterfly valves OK? **ANSWER:** Butterfly valves must be installed so they can be easily removed using simple tools and must be hand cleaned.
28. Can a plate cooler pinch valve hose go into a drain? **ANSWER:** The hose must be air gapped above the drain.

# APPENDIX A

## **3-A Accepted Practices for the Design, Fabrication, and Installation of Milking and Milk Handling Equipment, No. 606-05**

Reprinted with permission from the International Association for Food Protection,  
6200 Aurora Avenue, Suite 200W, Des Moines, IA 50322-2864.

Web site [www.foodprotection.org](http://www.foodprotection.org).

We encourage every installer of milking and milk handling equipment to have a complete set of 3-A Sanitary Standards and Accepted Practices.

To obtain 3-A Sanitary Standards and Accepted Practices go to  
<http://www.techstreet.com/3Agate.html>

# 3-A<sup>®</sup> Accepted Practices for the Design, Fabrication, and Installation of Milking and Milk Handling Equipment, Number 606-05

*Formulated by*  
*International Association of Food Industry Suppliers (IAFIS)*  
*International Association for Food Protection (IAFP)*  
*United States Public Health Service (USPHS)*  
*The Dairy Industry Committee (DIC)*  
*United States Department of Agriculture – Dairy Programs (USDA)*

It is the purpose of the IAFIS, IAFP, USPHS, DIC, and USDA in connection with the development of the 3-A Sanitary Standards Program to allow and encourage full freedom for inventive genius or new developments. Milking and milk handling equipment specifications heretofore or hereafter developed which so differ in design, materials, and fabrication or otherwise as not to conform to the following standards but which, in the fabricator's opinion, are equivalent or better, may be submitted for the joint consideration of the IAFIS, IAFP, USPHS, DIC and USDA at any time. Standard English is the official language of 3-A Sanitary Standards and 3-A Accepted Practices.

- |   |   |
|---|---|
| <p>A     <b>SCOPE</b></p> <p>A1     These 3-A Accepted Practices shall pertain to equipment used in a milking system that begins with the equipment applied to the cow to extract milk and continues to all components in the system exclusive of the container in which the raw milk is stored or from which the milk is removed from the dairy farm.</p> <p>A2     In order to conform to these 3-A Accepted Practices, milking and milk handling equipment shall conform to the following design, material, fabrication, and installation criteria.<sup>1</sup></p> <p>B     <b>DEFINITIONS (See Appendix, Section J, Figures 1 &amp; 2)</b></p> <p>B1     <i>Product:</i> Shall mean raw milk.</p> <p>B2     <i>Solutions:</i> Shall mean those homogeneous mixtures of chemical solute(s) and solvent used for flushing, cleaning, rinsing, and sanitizing.</p> <p>B3     <b>Surfaces</b></p> <p>B3.1   <i>Product Contact Surfaces:</i> Shall mean all surfaces which are exposed to the product and surfaces from which liquids may drain, drop, or be drawn into the product.</p> | <p>B3.2   <i>Solution Contact Surfaces:</i> Shall mean the interior surfaces of the equipment or system which are used exclusively for supply and recirculation of cleaning and/or sanitizing solutions, except those used to supply concentrated cleaning and/or sanitizing materials to the point of use.</p> <p>B3.3   <i>Nonproduct Contact Surfaces:</i> Shall mean all other exposed surfaces.</p> <p>B3.3.1 <i>Splash Contact Surfaces:</i> Shall mean other nonproduct contact surfaces that during normal use are subject to accumulation of soil and which require routine cleaning.</p> <p>B4     <b>Cleaning</b></p> <p>B4.1   <i>Mechanical Cleaning or Mechanically Cleaned:</i> Shall mean soil removal by impingement, circulation, or flowing chemical detergent solutions and water rinses onto and over the surfaces to be cleaned by mechanical means in equipment or systems specifically designed for this purpose.</p> <p>B4.1.1 <i>Cleaned In Place (CIP):</i> Shall mean mechanical cleaning of equipment, the cleanability of which has been sufficiently established such that all product or solution contact surfaces do not have to be readily accessible for inspection, i.e. silo-type tanks or welded pipelines.</p> <p>B4.2   <i>Manual (COP) Cleaning:</i> Shall mean soil removal</p> |
|---|---|

<sup>1</sup> Use current revisions or editions of all referenced documents cited herein.

when the equipment is partially or totally disassembled. Soil removal is effected with chemical solutions and water rinses with the assistance of one or a combination of brushes, nonmetallic scouring pads and scrapers, high or low pressure hoses and tank(s) which may be fitted with recirculating pump(s), and with all cleaning aids manipulated by hand.

## B5 Pipelines

B5.1 *Milk Line:* Shall mean rigid pipelines which have welded joints or sanitary fittings and are designed for mechanical cleaning and which are used for the dual function of transporting milk and air.

B5.2 *Wash Line:* Shall mean rigid pipelines which have welded joints or have sanitary fittings and are used exclusively for the supply and recirculation of cleaning and/or sanitizing solutions, except those used to supply concentrated cleaning and/or sanitizing materials to the point of use.

B5.3 *Main Air Line:* Shall mean the rigid pipe or tube from the vacuum pump through the sanitary trap to the receiver.

B5.4 *Milk Transfer Line:* Shall mean a pipe which performs the single function of transporting milk.

B5.5 *Pulsator Air Line:* Shall mean the rigid pipe or tube that supplies vacuum to the pulsator(s).

## B6 Component Equipment

B6.1 *Sanitary Fittings:* Shall mean welded or rolled-on fittings with gaskets to form joints designed for mechanical cleaning which form substantially smooth flush interior surfaces.

B6.2 *Air Injector:* Shall mean a mechanical valve used to admit air intermittently into the washing system to increase the cleaning action.

B6.3 *Short Pulse Tube:* Shall mean the flexible air hose or tube between the claw or unit mounted pulsator and the teatcup shell.

B6.4 *Claw:* Shall mean the sanitary manifold (which may include a reservoir or claw bowl) that spaces the teatcup assemblies in a cluster and connects them to the long milk tube and may include a manifold to connect the long pulse tube to the short pulse tubes.

B6.5 *Cluster:* Shall mean an assembly comprising teatcups and claw.

B6.6 *Teatcup Jettors:* Shall mean the manifold assembly used to supply cleaning solutions through the claw and teatcup assemblies for mechanical cleaning in the milking parlor.

B6.7 *Vacuum Tube:* Shall mean a flexible air tube or hose that connects a bucket milker to a vacuum line.

B6.8 *Long Pulse Tube:* Shall mean a flexible air tube or hose that connects a pulsator to a claw.

B6.9 *Milk Meter:* Shall mean in-line equipment that measures the quantity or rate of flow of milk from individual cows.

B6.10 *Long Milk Tube (Milk Hose):* Shall mean a flexible hose or tube that connects the claw or claw bowl to a bucket or a milk line or a milk transfer line.

B6.11 *Milk Inlet:* Shall mean a nipple on the milk line or milk transfer line.

B6.12 *Milk Cock (Milk Inlet Valve):* Shall mean an open-close device incorporated in the milk inlet.

B6.13 *Short Milk Tube:* Shall mean a tube that connects the teatcup liner to the claw inlet nipple.

B6.14 *Nipple:* Shall mean a short pipe projecting from the claw, pulsator, milking machine lid, or other part of the milking system apparatus.

B6.15 *Pipeline Milking Machine:* Shall mean a milking equipment system utilizing milk lines and/or milk transfer lines.

B6.16 *Receiver:* Shall mean a vessel that receives milk from the milk line or milk transfer line.

B6.17 *Releaser:* Shall mean a device that releases milk from under vacuum and discharges it to atmospheric pressure.

B6.18 *Sanitary Trap:* Shall mean a flow vessel that separates the milk side of a milking machine system from the vacuum supply side to keep milk and fluids out of the vacuum system and to prevent back-flow of fluids.

B6.19 *Slip-On Connectors:* Shall mean a nipple free of barbs over which a hose is positioned without any

- additional attachment.
- B6.20 *Stall Cock*: Shall mean the valve device on the pulsator air line to which the vacuum hose or pulsator is attached.
- B6.21 *Teatcup*: Shall mean the teatcup shell and liner or inflation.
- B6.22 *Teatcup liner or Inflation*: Shall mean a rubber or rubber-like flexible sleeve with mouthpiece and barrel which fits inside the teatcup shell. The liner may have an integral or separate short milk tube.
- B6.23 *Teatcup Shell*: Shall mean the metal or plastic case or shell in which the teatcup liner or inflation is enclosed.
- B6.24 *Transfer Station*: Shall mean a receptacle and piping or tubing system which conveys milk from the milking area to the container in which the milk is stored. Transfer stations are used with the pail or bucket type milking units.
- B6.25 *Vacuum Pump*: Shall mean an air pump(s) connected to a milking system that creates a suction and maintains partial vacuum.
- B6.26 *Bucket Milking Machine*: Shall mean a machine in which milk flows from the claw into a portable milk receiving bucket which is connected to the vacuum system.
- B6.27 *Distribution Tank*: Shall mean an air vessel or chamber, in the main air line between the vacuum pump and the sanitary trap, which acts as a manifold for other pipelines.
- B6.28 *Drop Lines for Mechanical Cleaning*: Shall mean those flexible hoses which connect wash lines to teatcup jetters or milk meters.
- B6.29 *Milk Cooling and Holding Tank*: Shall mean a vertical or horizontal cylindrical, rectangular, or oval or other equally satisfactorily shaped tank.
- B6.30 *Milking Parlor*: Shall mean a milking area where cows are present only when being milked.
- B6.31 *Milk Pump*: Shall mean a centrifugal or positive displacement pump which moves milk from the receiver to the milk holding tank.
- B6.32 *Pulsator*: Shall mean a device for producing cyclic pressure change inside a teatcup shell.
- B6.33 *Vacuum Milk Holding Tank*: Shall mean a milk cooling and holding tank which is under vacuum during milking.
- B7 *Simple Hand Tools*: Shall mean implements normally used by operating and cleaning personnel such as a screwdriver, wrench or hammer.
- C MATERIALS**
- C1 Metals**
- The materials of product contact surfaces of equipment included in the milking system for which there are 3-A Sanitary Standards or 3-A Accepted Practices shall conform to the material criteria of the applicable standards or accepted practices.
- C1.1 Other product contact surfaces shall be of stainless steel of the American Iron and Steel Institute (AISI) 300 Series<sup>2</sup> or corresponding Alloy Cast Institute (ACI) types<sup>3</sup> (See Appendix, Section H), or metal which under conditions of intended use is at least as corrosion resistant as stainless steel of the foregoing types, and is nontoxic and nonabsorbent, except that:
- C2 Nonmetals**
- C2.1 Glass may be used for milk lines, milk transfer lines, receivers, receiver air lines, claws, fittings, and elbows, and shall be of a clear, heat-resistant type.
- C2.2 Rubber and rubber-like materials may be used in sealing applications, long air hoses, milk hoses, short milk tubes, vacuum tubes, long and short pulse tubes, filter parts, teatcup liners, teatcup jetters, O-rings, drip deflectors, level sensing devices (probes), sensor insulators, and parts having the same functional purposes.
- C2.2.1 Rubber and rubber-like materials, when used for the above-specified application(s), shall conform to the applicable provisions of the 3-A Sanitary Standards for Multiple-Use Rubber and Rubber-Like Materials Used as Product Contact Surfaces in Dairy Equipment, Number 18-.
- 
- <sup>2</sup> The data for this series are contained in the *AISI Steel Products Manual, Stainless & Heat Resisting Steels*, Table 2-1. Available from the American Iron and Steel Society, 186 Thorn Hill Road, Warrendale, PA 15086 (724) 776-1535.
- <sup>3</sup> Steel Founders Society of America, Cast Metal Federation Building, 455 State Street, Des Plaines, IL 60016 (708) 299-9160.

- C2.3 Plastic materials may be used in sealing applications, transparent flexible tubing for transfer stations, milk hoses, short milk tubes, milk line fittings, vacuum tubes, long and short pulse tubes, plug-type valves, sight and light openings in product or solution pipelines, milk lines or wash lines, filter parts, teatcup liners, O-rings, drip deflectors, level sensing devices (probes), sensor insulators, teatcup jetters, metering devices, releasers, claws, pipeline drain assemblies, air injectors, buckets and bucket lids, float balls and milk inlets and parts having the same functional purposes.
- C2.3.1 Plastic materials when used for the above-specified application(s) shall conform to the applicable provisions of the 3-A Sanitary Standards for Multiple-Use Plastic Materials Used as Product Contact Surfaces for Dairy Equipment, Number 20-.
- C2.4 Bonded rubber and rubber-like materials and bonded plastic materials having product contact surfaces shall be of such composition as to retain their surface and conformational characteristics when exposed to the conditions encountered in the environment of intended use and in cleaning and bactericidal treatment.
- C2.5 The final bond and residual adhesive, if used, on bonded rubber and rubber-like materials and bonded plastic materials shall be nontoxic.<sup>4</sup>
- C2.6 Where materials having certain inherent functional purposes are required for specific applications, such as probe coatings and rotary seals, carbon and/or ceramic materials may be used. Carbon and/or ceramic materials shall be inert, nonporous, nontoxic, nonabsorbent, insoluble, resistant to scratching, scoring, and distortion when exposed to the conditions encountered in the environment of intended use and in cleaning and bactericidal treatment.
- C3 Solution contact surfaces shall be of stainless steel of the American Iron and Steel Institute (AISI) 300 Series or corresponding Alloy Cast Institute (ACI) types (See Appendix, Section H), or metal which under conditions of intended use is at least as corrosion resistant as stainless steel of the foregoing types, and is nontoxic and nonabsorbent, or of clear

heat resistant glass piping. Rubber and rubber-like materials or plastic materials conforming to C2.2.1 or C2.3.1 may be used for sealing applications and for short flexible takedown jumpers or slip-on connectors.

#### C4 Nonproduct Contact Surfaces

C4.1 All nonproduct contact surfaces shall be of corrosion-resistant material or material that is rendered corrosion resistant. If coated, the coating used shall adhere. All nonproduct contact surfaces shall be relatively nonabsorbent, durable, and cleanable. Parts removable for cleaning having both product contact and nonproduct contact surfaces shall not be painted.

C5 Main air lines and/or pulsator air lines shall be made of materials which will withstand periodic cleaning. If these lines are used as part of the product contact surface cleaning circuit, they must conform to Section C3.

C6 Paper gaskets shall not be used.

#### D FABRICATION

D1 The fabrication criteria of equipment included in the milking system for which there are 3-A Sanitary Standards or 3-A Accepted Practices shall be those of the applicable standards or accepted practices. (See Appendix, Section T.)

D2 Other equipment shall conform to the following fabrication criteria.

##### D2.1 Surface Texture

D2.1.1 All product and solution contact surfaces shall have a texture at least as smooth as a 32.0  $\mu\text{m}$   $R_a$  (0.80  $\mu\text{m}$   $R_a$ ) finish on stainless steel sheets and be free of imperfections such as pits, folds, and crevices in the final fabricated form (see Appendix, Section I), except that:

D2.1.1.1 The solution contact surfaces for castings for pumps shall be at least as smooth as on the GAR C-9 Cast Microfinish comparator, C-40 (200  $\mu\text{m}$  or 5.08  $\mu\text{m}$  RMS). (See Appendix, Section K.)

D2.2 All permanent joints in metallic product contact surfaces shall be continuously welded, except that:

D2.2.1 Recessless or rolled-on fittings may be used as

<sup>4</sup> Adhesives shall comply with 21 CFR 175 - Indirect Food Additives: Adhesives and Components of Coatings. Document for sale by the Superintendent of Documents, U.S. Government Printing Office, Washington, D.C. 20402 (202) 512-1800.

provided for in 3-A Sanitary Standards for Sanitary Fittings for Milk and Milk Products, Number 63-.

D2.2.2 Recessless or rolled-on fittings may be used when modifying or repairing existing on-site farm milk handling systems.

D2.2.3 These fittings shall be installed with no cracks or crevices and shall meet the surface texture specified in D2.1.1.

#### D2.3 Gaskets

D2.3.1 Gaskets having a product or solution contact surface shall be removable or bonded.

D2.3.2 Grooves in gaskets shall be no deeper than their width unless the gasket is readily removable and reversible for cleaning.

D2.3.3 Gasket grooves or gasket retaining grooves in product contact surfaces for removable gaskets shall not exceed 1/4 in. (6.35 mm) in depth or be less than 1/4 in. (6.35 mm) wide except those for standard O-rings smaller than 1/4 in. (6.35 mm), and those provided for in Section D2.9.

#### D2.4 Radii

D2.4.1 All internal angles of less than 135° on product contact surfaces shall have radii of not less than 1/4 in. (6.35 mm) except that:

D2.4.1.1 Smaller radii may be used when they are required for essential functional reasons, such as those in O-ring grooves, claw assemblies, and milking machine lids. In no case shall such radii be less than 1/32 in. (0.794 mm).

D2.4.1.2 The radii in gasket grooves, gasket retaining grooves, or grooves in gaskets, and those provided for in Section D2.9 and except for those for standard 1/4 in. (6.35 mm) and smaller O-rings, shall be not less than 1/8 in. (3.18 mm).

D2.4.1.3 The radii in grooves for standard 1/4 in. (6.35 mm) O-rings shall not be less than 3/32 in. (2.38 mm) and for standard 1/8 in. (3.18 mm) O-rings shall be not less than 1/32 in. (0.794 mm).

D2.4.2 The minimum radii for fillets of welds in product contact surfaces shall be not less than 1/4 in. (6.35 mm) except that the minimum radii for such welds may be 1/8 in. (3.18 mm) when the thickness of one

or both parts joined is less than 3/16 in. (4.76 mm).

#### D2.5 Openings in Covers

D2.5.1 All milk lines and/or milk transfer lines and other appurtenances entering through the lid or cover of the cooling and/or holding tank, and not permanently attached to the cover, shall be fitted with a sanitary drip deflector that overlaps the edges of the opening through the cover and is located as close as possible to the cover.

#### D2.6 Drainage

D2.6.1 The bottom of all product containers (surge tanks, distribution tanks, and receivers) which have a sanitary connection outlet shall have at least a 1/4 in. per ft. (21 mm per m) pitch to the outlet.

#### D2.7 Metal tanks

D2.7.1 Metal tanks used as surge tanks, distribution tanks, and receivers shall conform to 3-A Sanitary Standards for Uninsulated Tanks for Milk and Milk Products, Number 32-.

#### D2.8 Cleaning and Inspectibility

D2.8.1 Milking systems that are to be mechanically cleaned shall be designed so that the product contact surfaces of the milking system and all nonremoved appurtenances thereto can be mechanically cleaned and are easily accessible and readily removable for inspection and the following:

D2.8.1.1 Each separate cleaning circuit, including product and solution lines, shall be provided with a sufficient number of access points, such as valves, fittings or removable sections to make possible adequate inspections and examinations of representative interior surfaces.

D2.8.2 Product contact surfaces not designed to be mechanically cleaned shall be easily accessible for cleaning and inspection either when in an assembled position or when removed. Removable parts shall be readily demountable.

D2.8.3 All product contact and solution contact surfaces shall be cleanable, either when in an assembled position or when removed. System appurtenances shall be accessible for inspection. Removable parts shall be readily demountable.

- D2.9 Plastic or rubber hoses used under vacuum, such as vacuum tubes, long pulse tubes, milk hoses, short milk tubes, inflations, and drop lines for mechanical cleaning, may utilize slip-on connectors.
- D2.10 All sanitary fittings and connections shall conform to the 3-A Sanitary Standards for Sanitary Fittings for Milk and Milk Products, Number 63-, 3-A Sanitary Standards for Plug-Type Valves for Milk and Milk Products, Number 51-, 3-A Sanitary Standards for Thermoplastic Plug-Type Valves for Milk and Milk Products, Number 52-, or 3-A Sanitary Standards for Compression-Type Valves for Milk and Milk Products, Number 53-, except that plastic fittings and connections that conform to Section C2.3.1 and glass fittings and connections that conform to Section C2.1 may be used.
- D2.11 Lines and fittings for the application of air under pressure shall conform to the applicable provisions of 3-A Accepted Practices for Air Under Pressure in Contact with Milk, Milk Products, and Product Contact Surfaces, Number 604-.
- D2.12 **Springs**
- D2.12.1 Any coil spring having product contact surfaces shall have at least 3/32 in. (2.38 mm) openings between coils, including the ends when the spring is in the free position.
- D2.13 Bonded rubber and rubber-like materials and bonded plastic materials having product contact surfaces shall be bonded in a manner that the bond is continuous and mechanically sound so that when exposed to the conditions encountered in the environment of intended use and in cleaning and bactericidal treatment, the rubber and rubber-like material or the plastic material does not separate from the base material to which it is bonded.
- D2.14 **Nonproduct Contact Surfaces**
- D2.14.1 Nonproduct contact surfaces shall have a smooth finish, free of pockets and crevices, and be readily cleanable. Surfaces to be coated shall be effectively prepared for coating to assure adhesion.
- E **FABRICATION - SPECIFIC ITEMS**  
The following are requirements for specific items.
- E1 **Milking Machine Pails and Transfer Stations**  
A tipping handle, located near the bottom, shall be provided on a floor type pail. Handles and brackets shall be permanently attached to the equipment. A lid shall be provided for both floor and suspended-type pails. Bails, handles, chins, and legs on both types of milking machine pails shall be considered nonproduct contact surfaces.
- E1.1 Lids or covers shall be provided for milking machine pails, milk carrying pails, and transfer station receptacles. Lids on transfer station receptacles shall be self closing. All ungasketed lids shall have overlapping edges turned down at least 3/8 in. (9.52 mm) below the top of the milk pail or receptacle. The lids or covers on the milking machine pails, milk carrying pails, and transfer stations shall be pitched to an outside edge(s) so as to be free draining.
- E1.2 The transparent plastic tubing used in conjunction with a transfer station shall be one continuous piece.
- E1.2.1 Equipment for air drying transfer tubing shall be provided. The air drying equipment shall conform to the applicable provisions of the 3-A Accepted Practices for Air Under Pressure in Contact with Milk, Milk Products, and Product Contact Surfaces, Number 604-.
- E1.3 Pumps used for product contact, if supplied, shall conform to the 3-A Sanitary Standards for Centrifugal and Positive Rotary Pumps for Milk and Milk Products, Number 02-.
- E1.4 Pumps, when used, shall be actuated by a milk level sensing device. All product contact surfaces of the device shall be readily demountable for inspection and shall be located so that all of the product contact surfaces are reached by rinse, wash, and sanitizing solutions.
- E1.5 The carriage shall be constructed of smooth corrosion resistant material. Tires shall be smooth and without threads.
- E2 **Milker Claws**
- E2.1 Nipples for long and short milk tubes shall be flush with the interior surface of the claw bowl.
- E2.2 The claw shall be designed so that cleaning and sanitizing solutions will drain when the claw is in the cleaning and sanitizing position.
- E2.3 Automatic cluster removers, when used, shall shut the vacuum off to the claw prior to removal to prevent extraneous material from being drawn into the cluster.

The design and/or adjustment shall be such that the cluster is not dragged across the floor at removal.

- E3 Sanitary Check Valves**
- E3.1 A bucket type milking machine shall be provided with a sanitary check valve or other device that will prevent moisture or any contaminating substance from entering the milk from the vacuum system. A sanitary check valve or other device that will pass the test methods found in Appendix, Section J is considered to meet this provision.
- E3.2 The movable portion of the sanitary check valve shall be of one piece construction or the parts shall be bonded together.
- E4 Filters**
- E4.1 Filters shall conform to the 3-A Sanitary Standards for Milk and Milk Products Filters Using Disposable Filter Media, Number 10-.
- E4.2 Wire mesh or woven material shall not be used for the filter medium support.
- E5 Milk Lines and/or Milk Transfer Lines and/or Wash Lines**
- E5.1 All solution contact surfaces shall be at least as smooth as a 32.0  $\mu\text{in. } R_a$  (0.80  $\mu\text{m } R_a$ ) finish on stainless steel sheets except as provided in Section D2.1.1.1.
- E5.2 Permanently mounted product and solution pipelines shall have sanitary fittings or welded joints.
- E5.3 All product contact sanitary pipeline (tubing) shall conform to the 3-A Sanitary Standards for Polished Metal Tubing for Dairy Products, Number 33- or be of a clear, heat resistant glass.
- E5.4 Milk lines shall be supported so that they remain in alignment and position. (See Appendix, Section S.) The support system shall be designed so as to preclude electrolytic action between support(s) and milk line(s).
- E5.5 Each separate cleaning circuit, including product and solution pipelines (wash lines), shall be provided with a sufficient number of access points, such as valves, fittings, or removable sections to make possible adequate inspection and examination of representative interior surfaces. All mechanically cleaned milk line product contact surfaces shall be exposed to cleaning and sanitizing solutions during cleaning.
- E5.6 The milker unit (cluster and long milk tube) cleaning manifold shall not be located in the milk line.
- E5.7 Milk lines and wash lines shall be self-draining except for normal adherence, and shall have a minimum continuous slope of at least 1.0 in. per 10.0 ft (8.3 mm per m) from a high point. (Also see Section E8.2 and E8.5.)
- E5.8 Milk inlets and milk inlet valves, where provided, shall be self-draining into the milk lines and/or milk transfer line and installed so that milk enters the upper half of the milk line. All milk inlet valves shall be supplied with closures which are readily applied and are of sanitary design.
- E5.9 The milk line and/or milk transfer line couplings or unions shall not be located in openings in walls, solid partitions, etc. through which the milk line and/or milk transfer lines pass. Where necessary, protective shields shall be used. The openings between the milk line and wall shall be protected to prevent the entrance of flies and other insects into the milkroom.
- E5.10 Milking systems shall be physically disconnected from the cleaning make-up vats during milking to avoid contamination by solution in the vat.
- E5.11 Milk lines shall be installed so that the vertical distance from the platform on which the cow stands to the center of the milk line, does not exceed 7.0 ft (2.1 m) when milk is moved by vacuum directly from the milker unit assembly to the milk line except for crossovers. Opaque long milk tubes shall not exceed 8.0 ft (2.4 m) in length.
- E5.12 There shall be no risers in the milk line. Any upward slope encountered by the milk moving toward the receiver is considered a riser. Vertical sanitary pipelines, such as cross over pipelines, which do not convey milk are not considered risers.
- E5.13 In a pipeline milking system, there shall be no cross-connection(s) between the safe water supply and any unsafe or questionable water supply, or any source of pollution through which the safe water supply might become contaminated. For example, a connection between the water supply piping and solution make-up tank, unless protected by an air gap or effective back-flow preventer, constitutes a violation of this practice.

- E5.14 A milk transfer line connecting the milk pump or releaser and milk cooling and holding tank shall be a rigid pipe or tube with welded joints or permanently installed sanitary fittings.
- E6 Vacuum Pumps**
- E6.1 Oil-containing exhaust from a vacuum pump shall not terminate in a milking barn, stable, parlor, milkroom or feedroom.
- E7 Vacuum Regulators and Air Admission**
- E7.1 During the milking cycle a regulator shall not admit air directly into the milk line.
- E7.2 Air may be admitted into the milk line and/or milk transfer line for purposes of "shut down" by valves or other acceptable means located in the milkroom only. A valve for "shut down" purposes may not be installed in nonproduct contact lines unless a check valve is installed adjacent to the sanitary trap and in such a manner that will permit air to travel only to the vacuum pump.
- E7.3 Air admission bleed holes (or air vents), if provided, shall be in the upper half of the claw or claw bowl when it is in the milking position or in the teatcup assembly.
- E7.4 An air injector, if provided, shall be located to admit clean air into the pipeline during the washing process. The timing and air-to-water ratio shall be adjusted so all surfaces are exposed to wash solution with enough turbulence to clean the system. The air injector shall be designed, installed, and operated so that air is not admitted during milking. Air injectors shall be located in the milk house or room of equivalent cleanliness, or shall be provided with an appropriate filter and properly protected from contamination. Air injectors mounted on the milk line shall be of sanitary design.
- E8 Main Air Lines and/or Pulsator Air Lines**
- E8.1 Main air lines and/or pulsator air lines shall be supported in such a manner that the lines will properly drain.
- E8.2 Main air lines and/or pulsator air lines shall be sloped at least 1/2 in. in 10 ft (4.2 mm per m), preferably in the direction of air flow.
- E8.3 An automatic drain valve or a self draining sanitary trap shall be installed at the bottom of all risers which are not self-draining.
- E8.4 Stall cocks shall enter the upper half of the line.
- E8.5 In a pipeline milking machine, a self-draining sanitary trap shall be provided whenever the milk line or a permanently installed solution pipeline (wash line) is connected to a vacuum supply line. The trap shall be installed adjacent to the milk receiver, releaser, wash vacuum pipeline or vacuum milk holding tank and connected by readily disassembled sanitary piping. From the top intersection of the outlet on the receiver, the vertical rise of this connection shall not exceed 12 in. (30.5 cm) as measured to the bottom of the connecting elbow. The connecting sanitary piping shall slope toward the sanitary trap at least 1/2 in. (13 mm) in the first 2 ft (61 cm) and the remainder of the pipe shall slope a minimum of 0.8%. The sanitary trap shall be installed so that any liquid collected in the sanitary trap cannot get back into the receiver, releaser, or vacuum milk holding tank. Sanitary traps designed for mechanical cleaning may be cleaned by reverse flow.
- E8.6 If a distribution tank is used, it shall be self-draining except for normal adherence.
- E9 Milk Receiver, Pump, and Releaser**
- E9.1 The milk level sensing device shall be designed so that milk will not reach the lowest inlet in the milk receiver.
- E9.2 When a centrifugal or positive rotary type milk pump is used to remove the milk from the receiver, it shall conform to the 3-A Sanitary Standards for Centrifugal and Positive Rotary Pumps for Milk and Milk Products, Number 02-. The pump shall be located so that it is readily accessible for cleaning and/or inspection.
- E9.3 The pump shall be actuated by a level sensing device. All product contact surfaces of the device shall be readily demountable for inspection and shall be located so that all of the product contact surfaces are reached by the rinse and wash solutions.
- E9.4 A releasing mechanism, when provided, shall be of a sanitary design, and operated so that the milk will not reach the lowest milk inlet of the receiver during milking.

- E9.5 The pump and interconnecting piping shall be installed so that they are self-draining except for normal adherence. Drains shall terminate above the floor and shall not be connected to sewage lines.
- E10 The teatcup jettors in the parlor shall be covered during milking.
- E10.1 Cluster cleaning devices such as teatcup jettors, when installed outside the milkroom, shall be constructed as to prevent insects, rodents, dirt, dust, and other contaminants from gaining access to milk contact surfaces and solution contact surfaces. They shall provide complete drainage, except for normal adherence, of clusters, long milk tubes, and solution contact surfaces.
- E11 **Automatic Backflush Systems**
- E11.1 When backflush is used, it shall include a valve between the claw and the milk inlet which provides a complete separation, with an air gap, between the solution inlet and milk line.
- E11.2 The backflush cycle shall include a pre- and post-rinse with safe water.
- E11.3 After final rinse, any remaining water shall be blown from the cluster with compressed air or removed from the unit by vacuum. This is to be accomplished before the valve returns to the milking position.
- E11.4 If compressed air is used to blow water from the unit or injected into the sanitizer or rinse solution, the air must be produced using equipment conforming to the 3-A Accepted Practices for Supplying Air Under Pressure in Contact with Milk, Milk Products and Product Contact Surfaces, Number 604-.
- E12 **Heat Exchangers**
- E12.1 When plate heat exchangers are used as milk coolers in milking systems, they shall conform to 3-A Sanitary Standards for Plate Heat Exchangers for Milk and Milk Products, Number 11-.
- E12.2 When tubular heat exchangers are used as milk coolers in milking systems, they shall conform to 3-A Sanitary Standards for Tubular Heat Exchangers for Milk and Milk Products, Number 12-.
- E12.3 Other types of heat exchangers, such as refrigerated receivers, if used as milk coolers in milking systems, shall conform to the applicable criteria in Sections C and D of 3-A Accepted Practices for the Design, Fabrication and Installation of Milking and Milk Handling Equipment, Number 606-.
- E12.4 Recirculated cold water which is used in plate or tubular heat exchangers shall be from a safe source, shall be nontoxic, and shall be protected from contamination. Such water shall be tested semiannually and shall conform to appropriate bacteriological standards.
- F **MANUFACTURER'S INSTRUCTIONS**
- F1 The manufacturer shall furnish instructional charts and literature on milking systems giving the maintenance schedules and operational instructions. This shall include the recommended assembly and disassembly procedures of all components. It shall also include lubrication and maintenance schedules for vacuum pumps, milk pumps, pulsators, and vacuum regulators.
- G **APPLICATION TO INSTALL PIPELINE MILKING MACHINES**
- G1 Prior to the installation of a pipeline milking machine, the producer shall first make application on a suitable form, as prescribed by the control authority, or in the absence of a required form, on a form as suggested herein (See Appendix, Section U). The producer shall provide the control authority with two copies of the necessary details and flow diagrams. Approval of the application shall be obtained prior to the starting of installation.
- G2 Changes in existing milking systems, affecting capacity or arrangement, shall be submitted to the control authority.
- APPENDIX**
- NOTE:** This Appendix is an adjunct to the preceding section of these practices. Its purpose is to provide supplemental information and nonnormative guidance in the design, fabrication and installation of milking machines.
- H **STAINLESS STEEL MATERIALS**
- Stainless steel conforming to the applicable composition ranges established by AISI for wrought products, or by ACI for cast products, should be considered in compliance with the requirements of Section C1 herein. Where welding is involved, the carbon content of the stainless steel should not exceed

0.08 %. The first reference cited in C1.2 sets forth the chemical ranges and limits of acceptable stainless steel of the 300 Series. Cast grades of stainless steel corresponding to types 303, 304, and 316 are designated CF-16F, CF-8, and CF-8M, respectively. The chemical compositions of these cast grades are covered by ASTM<sup>5</sup> specifications A351/A351M, A743/A743M and A744/A744M.

## I **PRODUCT CONTACT SURFACE FINISH**

Surface finish equivalent to 150 grit or better as obtained with silicon carbide, properly applied on stainless steel sheets, is considered in compliance with the requirements of Section D1 herein. A maximum  $R_a$  of 32.0  $\mu\text{in.}$  (0.80  $\mu\text{m}$ ), when measured according to the recommendations in American National Standards Institute (ANSI)/American Society of Mechanical Engineers (ASME)<sup>6</sup> B46.1 - *Surface Texture*, is considered to be equivalent to a No. 4 finish.

## J **PROCEDURES FOR TESTING SANITARY CHECK VALVE PERFORMANCE ON BUCKET-TYPE MILKERS**

J1 This procedure has been devised to test the performance of the sanitary check valve on bucket-type milking machines using a laboratory installation of the vacuum system. The only variations in the vacuum system used in this test (See Figure 1) from that used on dairy farms are: (a) a stall cock between the vacuum pump and the controller, as a means of controlling the vacuum, and (b) location of a vacuum gauge between the two stall cocks to which the units are attached during the test. The test should be conducted in the following manner using only the facilities outlined in the accompanying drawing:

J1.1 Set up pump, controller, trap, and stall cocks as indicated in Figure 1.

J1.2 Assemble two clean, dry milking machine units.

J1.3 Start the vacuum pump. Attach the vacuum tube to the stall cocks and apply vacuum to both units. Adjust the vacuum and pulsator speed to those recommended by the manufacturer.

J1.4 Reduce the vacuum in the system by opening the vacuum controlling valve at the pump until the needle on the gauge just starts to drop, not exceeding 1/2 in. of mercury (1.72 kPa) vacuum below the normal milking vacuum recommended by the manufacturer. (See step J1.3.)

J1.5 While the units are under vacuum, inject 5 mL of water with a syringe into the vacuum tubes of each unit, approximately 4 in. (101.6 mm) from the check valve.

J1.6 Admit air through the teatcups to one of the units to produce a momentary 4 in. of mercury (13.7 kPa) drop in vacuum (or the maximum drop permitted by the design of the machine), indicated on the vacuum gauge.

J1.7 Close the stall cock to which the vacuum tube of this unit is attached, remove the vacuum tube, and release the vacuum in the pail in the normal manner. (The vacuum tube must be maintained in a position favoring drainage toward the check-valve, as is the case when a unit is routinely moved from one stall cock to another.) The pail or container lid is not to be removed.

J1.8 Immediately attach this unit again to the stall cock, open stall cock, and re-establish the normal operating vacuum.

J1.9 Follow steps J1.6, J1.7 and J1.8 with the other unit.

J1.10 Repeat steps J1.5 to J1.8 inclusive, alternatively with the two units, five additional times (so that 30 mL of water will have been injected into each air hose.) Then release the vacuum and carefully remove and examine the lid, the check valve, and the interior of the pail of each unit, separately. The presence of moisture on the underside of the check valve, on the underside of the lid, or in the pail indicate failure of the check valve to function effectively in preventing backflow of potential contamination and indicates nonconformance to the requirement of E3.1.

## K **The GAR C-9 Scale For Visual Comparison**

K1 The GAR C-9 Cast Microfinish Comparator<sup>7</sup> is used to evaluate surface roughness of metallic castings. The GAR C-9 Scale provides a measure of the degree of smoothness typical for alloy castings made by

<sup>5</sup> Available from ASTM, 100 Barr Harbor Drive, West Conshohocken, PA 19428-2959. Phone: (610) 832-9500.

<sup>6</sup> Available from the American Society of Mechanical Engineers, 345 East 47th Street, New York, NY 10017-2392 (212) 705-7722.

<sup>7</sup> Available from GAR Electroforming Division, Box 340, Danbury, CT 06813-0340 (203) 744-4300.

currently available casting methods. The GAR C-9 Scale consists of nine RMS surface roughness finishes covering a range from 20  $\mu\text{in.}$  (0.51  $\mu\text{m}$ ) to 900  $\mu\text{in.}$  (22.9  $\mu\text{m}$ ). The scales applicable for investment castings are the C-20, C-30, and C-40 having corresponding RMS values of 60  $\mu\text{in.}$  (1.52  $\mu\text{m}$ ), 120  $\mu\text{in.}$  (3.05  $\mu\text{m}$ ), and 200  $\mu\text{in.}$  (5.08  $\mu\text{m}$ ). Areas of transition, such as chamfers, fillets, beads, etc., may conform to the next roughest scale.

## L **INSTALLING, SIZING AND PERFORMANCE GUIDELINES**

The installing, sizing, and performance guidelines outlined in American Society of Agricultural Engineers (ASAE) Standard: ASAE S-518 Milking Machine Installations, Construction and Performance<sup>8</sup> should be followed.

## M **MAIN AIR LINES AND/OR PULSATOR AIR LINES**

M1 Pipe and fittings used in main air lines and/or pulsator air line installations should be capable of withstanding vacuums of 25.0 in. (635 mm) of mercury without collapsing.

M2 Pulsator air lines should be looped to (1) a vacuum distribution tank or (2) a vacuum pulsator header line. A single header line should be a minimum of one size larger than the pulsator air line, unless the pulsator air line is sized larger than the minimum size specified in ASAE S-518. (See Appendix, Section L.)

## N **MILK LINE AND VACUUM SYSTEM CAPACITY**

N1 The milk line size should be deemed to be sufficient if, upon installation of a milking system, it meets the maximum milk line vacuum drop in accordance with Appendix, Section L.

N2 The vacuum system should be deemed to have sufficient capacity if, upon installation of a milking system, it meets the vacuum capacity and reserve performance criteria in accordance with Appendix, Section L.

## O **OPERATION, MAINTENANCE, AND SERVICE**

### O1 **Installation Check**

O1.1 It is recommended that immediately after installing, the installer should perform the dynamic milk test according to ASAE EP 445 - Test Equipment and Its Application for Measuring Milk Handling Equipment.

### O.2 **Service Check**

O2.1 It is strongly recommended that a complete service check and milking system performance evaluation be performed by an authorized milking machine dealer on an hourly use basis as recommended by the machine manufacturer or at least once a year. The suggested test should include (1) operating vacuum level, (2) vacuum pump capacity, and (3) effective reserve. It is highly desirable that a service report and milking system test report be supplied by the milking machine manufacturer and followed closely by their authorized dealer during the service check. A copy of the completed report should be furnished to the owner.

### O3 **Vacuum System**

The following recommendations, if followed, should aid in trouble-free operation of the vacuum system.

#### O3.1 **Vacuum Pump**

O3.1.1 Use only oil recommended by the manufacturer and maintain it at proper level. Change oil as frequently as recommended by the manufacturer.

O3.1.2 Consult a qualified dealer and the control authority before adding units to a milking system.

O3.1.3 Keep pulleys and belts free of oil and grease. Check the operator's manual for the proper belt tension. Keep shields and guards in place.

O3.2 Check the pulsator(s) as recommended by the manufacturer to see that it is properly adjusted.

O3.3 Check vacuum tubes and main air lines and/or pulsator air lines weekly, and clean as needed. Any leak in the vacuum pipeline should be corrected immediately.

O3.4 Check for vacuum leaks in all stall cocks, milk inlets, valves, gaskets, and other fittings.

O3.5 Check and clean vacuum regulator and sanitary traps weekly.

### O4 **Milker Units**

O4.1 Teatcup liners or inflations should be changed as

<sup>8</sup> Available from American Society of Agricultural Engineers, 2950 Niles Road, St. Joseph, MI 49085-9659 (616) 429-0300.

recommended by the manufacturer and damaged parts should be replaced immediately.

- O4.2 Only milk hoses, short milk tubes, short pulse tubes, long pulse tubes, and vacuum tubes of the recommended inside diameter should be used. Hoses and tubes should be kept free of obstructions and kinks.

## P **RELEASER**

- P1 The operation of the releaser should not cause the vacuum in the system to drop more than 1 in. (25.4 mm) of mercury.

## Q **TRANSFER STATIONS**

- Q1 To prevent excessive agitation and incorporation of air into the milk, pump-type stations should be equipped with level sensing devices to start and stop the pump motor. Vacuum operated stations should be equipped with check valves for the same purpose.

## R **CLEANING AND SANITIZING PROCEDURES**

- R1 A rinsing, cleaning, and sanitizing regimen which has been demonstrated to be effective should be employed. Prior to installation, a description of the cleaning regimen that has been determined to be effective should be made available to the producer. Because of the possibilities of corrosion, the recommendations of the cleaning compound manufacturer should be followed with respect to the time, temperature, and the concentration of specific detergent solutions and bactericides. To insure proper strength of solution and to avoid corrosion, the cleaning compound should be completely dissolved or dispersed prior to circulation. One regimen found to be satisfactory is as follows:

- R1.1 Immediately after concluding each milking, all connections between wash lines and milking equipment are made; equipment which is not included in the cleaning circuit is removed, the openings are capped, by-pass connections are made, and lines are rinsed thoroughly with tepid water at 90° to 105°F (32° to 40°C) entering circuit, continuously discarding the water at the downstream end of the solution return line until the discarded effluent is clear.

- R1.2 All solution and product contact surfaces not cleanable by mechanical cleaning procedures such as valves, slip joints, milk inlets, etc. should be cleaned manually.

- R1.3 An effective detergent solution should be circulated for a period of time at a concentration and temperature capable of effectively removing the soil residue in the circuit.

- R1.4 The detergent solution should be thoroughly rinsed from the circuit with an acid solution.

- R1.5 Immediately prior to the next milking, the line should be rinsed with clean water to which an approved sanitizing agent has been added. Then let drain before starting to milk.

- R2 Provisions should be made for adequate warm water under pressure to be available for cleaning the outside or nonproduct contact surfaces of the cluster including tubes. Dismantling for replacing rubber parts and/or manual cleaning of product contact surfaces should be done in the milkroom.

- R3 Provide means by which milk measuring devices which are not mounted permanently on the milking system but are used occasionally (for example, monthly) can be cleaned per manufacturer's recommendations.

- R4 Water heating capacity is considered adequate if the detergent solution in the wash vat is maintained at a minimum of 120°F (50°C). Manufacturer's recommendations for water requirements should be followed. Use the information below to determine the amount of water to wash the milking system.

### R4.1 **Hot Water Requirements**

Calculate the amount of hot water in the vat for washing per the following table. The amounts are valid for an ambient temperature down to 50°F (10°C) and when the water temperature is at least 160°F (71.1°C) at the start of the washing cycle, i.e. start of vacuum pump.

Component	Water Requirement
1 1/2 in. (33.10 mm) Drawlines, Wash Lines, and Milk Lines	0.4 gal/10 ft (0.5 L/m)
2 in. (50.80 mm) Drawlines, Wash Lines, and Milk Lines	0.6 gal/10 ft (0.7 L/m)
2 1/2 in. (63.50 mm) Milk Lines	0.8 gal/10 ft (1.0 L/m)
3 in. (76.20 mm) Milk Lines	1.2 gal/10 ft (1.5 L/m)
2 in. (50.80 mm) Discharge Line	1.4 gal/10 ft (1.7 L/m)
Weigh Jar	1.0 gal (3.78 L)/unit
Milk Meter	0.5 gal (1.89 L)/unit
Receiver	3.0 gal (11.34 L)/receiver
Vat	Additional 7.0 gal (26.5 L) or 25% of above (use larger value)

At colder ambient temperature, wash with more hot water or start at a higher water temperature. For example, at 30°F (-1.1°C) ambient temperature, 20-25% more water must be added or wash must start at 175° to 180°F (79.4° to 82.2°C). If wash starts at a lower 150°F (65.6°C) water temperature, add about 25% more hot water.

## S MILK LINE OR WASH LINE SUPPORTS

S1 Permanently installed pipeline supports should not be suspended from ceiling or joists in barns in which heavy feed, etc. is stored overhead. Supports should be spaced no more than 10 ft (3050 mm) apart. A support should be provided within 2 ft. (610 mm) of every direction change.

## T REFERENCES

- T1 3-A Sanitary Standards for Centrifugal and Positive Rotary Pumps for Milk and Milk Products, Number 02-.
- T2 3-A Sanitary Standards for Milk and Milk Products Filters Using Disposable Filter Media, Number 10-.
- T3 3-A Sanitary Standards for Plate Type Heat Exchangers for Milk and Milk Products, Number 11-.
- T4 3-A Sanitary Standards for Tubular Heat Exchangers for Milk and Milk Products, Number 12-.
- T5 3-A Sanitary Standards for Farm Milk Cooling and Holding Tanks, Number 13-.
- T6 3-A Sanitary Standards for Multiple-Use Rubber and Rubber-Like Materials Used as Product Contact Surfaces in Dairy Equipment, Number 18-.
- T7 3-A Sanitary Standards for Multiple-Use Plastic Materials Used as Product Contact Surfaces for Dairy Equipment, Number 20-.
- T8 3-A Sanitary Standards for Farm Milk Storage Tanks, Number 30-.
- T9 3-A Sanitary Standards for Uninsulated Tanks for Milk and Milk Products 32-.
- T10 3-A Sanitary Standards for Polished Metal Tubing for Dairy Products, Number 33-.

- T11 3-A Sanitary Standards for Plug-Type Valves for Milk and Milk Products, Number 51-.
- T12 3-A Sanitary Standards for Thermoplastic Plug-Type Valves for Milk and Milk Products, Number 52-.
- T13 3-A Sanitary Standards for Compression-Type Valves for Milk and Milk Products, Number 53-.
- T14 3-A Sanitary Standards for Sanitary Fittings Used for Milk and Milk Products, Number 63-.
- T15 3-A Sanitary Standards for Sensor and Sensor Fittings and Connections Used on Fluid Milk and Milk Products Equipment, Number 74-.
- T16 3-A Accepted Practices for Supplying Air Under Pressure in Contact with Milk, Milk Products, and Product Contact Surfaces, Number 604-.

## U APPLICATION TO INSTALL PIPELINE MILKING SYSTEMS

- U1 After application has been made, as in Section G, the applicant should be notified promptly of any necessary changes.
- U2 Each "type" of a manufacturer's standards unit may be made available by the dealer to the proper control authority, for general approval for installation in the control authority's jurisdiction at anytime. It is recognized that any manufacturer's so-called standards does not fit all operating conditions of all users. Therefore, if any installation requires deviations from the standards already generally approved for use in the jurisdiction, the details of all deviations must be submitted with the initial application for installation and approval received prior to the installation. It is urged that deviation details thus submitted be acted upon by the control authority promptly after being received.
- U3 It is recommended that all milk control authorities adopt an "Application to Install or Modify a Milking System" form.

---

**These practices are effective November 24, 2002.**

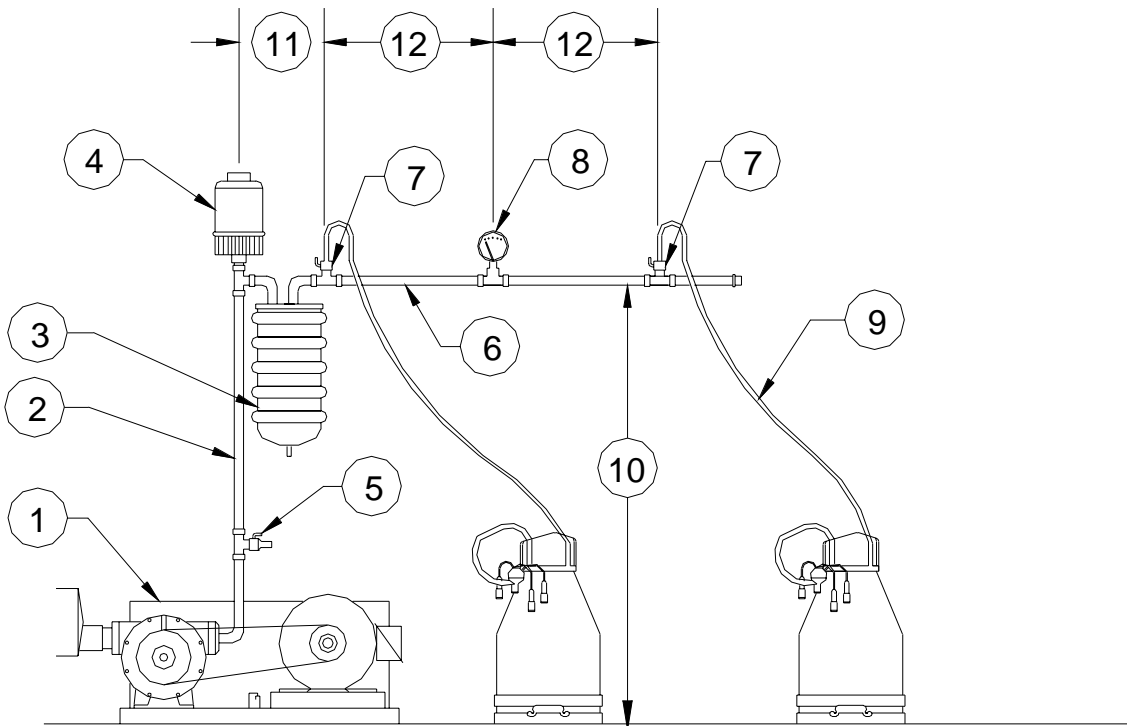

1. VACUUM PUMP
2. 1" PIPE
3. SANITARY TRAP
4. REGULATOR
5. VALVE FOR CONTROLLING VACUUM
6. 1" PIPE
7. STALL COCK
8. VACUUM GAUGE
9. VACUUM TUBES TO DRAIN TOWARD CHECK VALVE
10. 60"
11. 12"
12. 18"

## NOTE:

1. INSTALL REGULATOR AND VACUUM GAUGE PER MANUFACTURERS SPECIFICATIONS.
2. STALL COCKS TO BE POSITIONED PER MANUFACTURERS SPECIFICATIONS.

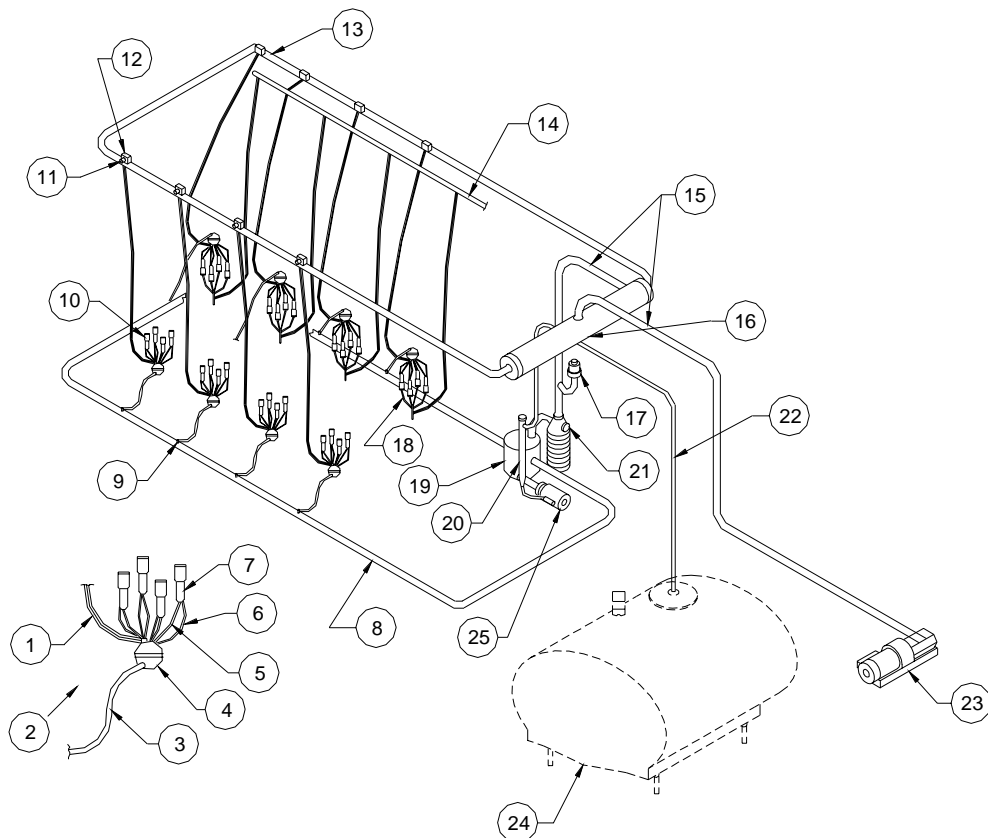

### PIPELINE MILKING SYSTEM

1. LONG PULSE TUBE
2. MILKING UNIT
3. LONG MILK TUBE (MILK HOSE)
4. CLAW
5. SHORT MILK TUBE
6. SHORT PULSE TUBE
7. TEATCUP SHELL
8. MILKLINE
9. MILK INLET
10. MILKING UNITS
11. STALLCOCK
12. PULSATOR
13. PULSATOR AIRLINE
14. WASHLINE
15. MAIN AIRLINE
16. DISTRIBUTION TANK
17. REGULATOR (CONTROLLER)
18. TEATCUP JETTER
19. RECIEVER
20. MILK FILTER
21. SANITARY TRAP
22. MILK DELIVERY (TRANSFER) LINE
23. VACUUM PUMP
24. MILK COOLING AND HOLDING TANK
25. MILK PUMP

**APPLICATION TO INSTALL OR MODIFY A MILKING SYSTEM**

Date: \_\_\_\_\_

Name of Producer: \_\_\_\_\_

Address: \_\_\_\_\_

State and Zip Code: \_\_\_\_\_

Phone/Fax/E-mail: \_\_\_\_\_

Producer's Regulatory License or Permit Number: \_\_\_\_\_

Milk Dealer or Buyer: .....

I HEREBY MAKE APPLICATION FOR PERMISSION TO INSTALL OR MODIFY A MILKING SYSTEM TO BE MECHANICALLY CLEANED IN PLACE. THIS EQUIPMENT WILL CONFORM TO OR EXCEED 3-A ACCEPTED PRACTICES FOR THE DESIGN, FABRICATION, AND INSTALLATION OF MILKING AND MILK HANDLING EQUIPMENT, NUMBER 604-.

**I INSTRUCTIONS:**

- A. All blanks that apply to this installation must be completed.
- B. This application must be accompanied by a detailed legible drawing of the milking system showing the following:
- |                                    |                        |                                     |
|------------------------------------|------------------------|-------------------------------------|
| 1. High Point                      | 4. Air Injector(s)     | 7. Milk Cooling and Holding Tank(s) |
| 2. Direction of Milk Flow          | 5. Inspection Point(s) | 8. Milk Pre-Cooler(s)               |
| 3. Receiver(s) or Transfer Station | 6. Wash Vat(s)         |                                     |

**II FABRICATION OF MILKING SYSTEM:****A Milk Line:**

- |                           |   |
|---------------------------|---|
| 1. Material(s) _____      | 6. Number of Slopes _____                   |
| 2. Diameter _____ in.(mm) | 7. Slope _____ in. per 10 ft (mm per m)     |
| 3. Length _____ ft (m)    | 8. High Line _____                          |
| 4. Welded _____           | 9. Maximum Height from Floor _____ in. (mm) |
| 5. Gasketed _____         | 10. Low Line _____                          |

**B Receiver:**

- |  |  |
|--|--|
| 1. Number of Inlets _____              | 3. Size of Vacuum Inlet _____ in.(mm)              |
| 2. Size of Milk Inlet(s) _____ in.(mm) | 4. Sanitary Trap: <b>Yes</b> _____ <b>No</b> _____ |

**C Auxiliary Milking Equipment:****Number Brand**

- |                              |                             |
|------------------------------|-----------------------------|
| 1. Milk Meter(s)             | _____                       |
| 2. Milk Weighing Device(s)   | _____                       |
| 3. Automatic Take-Off        | _____                       |
| 4. Automatic Backflush       | _____                       |
| 5. End of Milking Indicators | _____                       |
| 6. Milk Filtration           | _____                       |
| 7. Transfer Station          | Vacuum _____ Electric _____ |
| 8. Other (specify) _____     | _____                       |

**D Vacuum System:**

1. Main Air Line **Material** \_\_\_\_\_ **Diameter** \_\_\_\_\_ in.(mm) **Length** \_\_\_\_\_ ft (m)
2. Pulsator Air Line **Material** \_\_\_\_\_ **Diameter** \_\_\_\_\_ in. (mm) **Length** \_\_\_\_\_ ft (m)
3. Automatic Drains in Pulsator Air Lines **Yes** \_\_\_\_\_ **No** \_\_\_\_\_
4. Number of Clusters \_\_\_\_\_
5. Vacuum Pump(s) **Brand** \_\_\_\_\_ **Model(s)** \_\_\_\_\_ **hp (kJu)** \_\_\_\_\_
6. Total Vacuum Pump Capacity \_\_\_\_\_ CFM/ASME at 15 in. Hg. (51.4 kPa)
7. Vacuum Regulator **Brand** \_\_\_\_\_ **Model** \_\_\_\_\_
8. Number of Distribution Tank(s) \_\_\_\_\_
9. Other (specify) \_\_\_\_\_

**E Milk Cooling and Storage System:**

1. Pre-Cooler \_\_\_\_\_ **Brand(s)** \_\_\_\_\_ **Type** \_\_\_\_\_ **Number** \_\_\_\_\_
2. Type of Coolant(s) \_\_\_\_\_
3. Milk Cooling & Holding Tank **Brand** \_\_\_\_\_ **Model** \_\_\_\_\_ **Serial No.** \_\_\_\_\_  
**Milk** \_\_\_\_\_  
**Capacity** \_\_\_\_\_ **Cooling Capacity BTU/hr (kJu/h)** \_\_\_\_\_

**F Cleaning and Sanitizing System:**

NOTE: Water temperature of the wash cycle must be maintained at 120°F (49°C) or higher.

1. Automatic \_\_\_\_\_ Manual \_\_\_\_\_
2. Automatic Pre-Rinse Diverter Valve \_\_\_\_\_
3. Wash Procedure **Pre-Rinse** \_\_\_\_\_ gallons (L)  
**Wash Cycle** \_\_\_\_\_ gallons (L) **Time** \_\_\_\_\_ minutes  
**Acid/Post Rinse** \_\_\_\_\_ gallons (L)  
**Sanitize** \_\_\_\_\_ gallons (L)
4. Teatcup Jetters **Yes** \_\_\_\_\_ **No** \_\_\_\_\_

**G Water Heating Equipment:**

1. Type of Heater **Electric** \_\_\_\_\_ **Gas** \_\_\_\_\_ **Other** \_\_\_\_\_
2. Capacity of Heater \_\_\_\_\_ gallons (L)
3. Recovery Rate Gal/HR/100°F (38°C) Rise \_\_\_\_\_ gallons (L)
4. Additional Water Heating \_\_\_\_\_ **Type** \_\_\_\_\_

**H Manually Cleaned Components:** (Circle all that apply)

Diverter Plug(s)                      Manual Shut-Off Valve(s)                      Milk Tank Outlet Valve(s)

List other components in this system: \_\_\_\_\_

**I Physical Separation of Wash System (Lines) From:**

1. Milking System During Milking **Yes** \_\_\_\_\_ **No** \_\_\_\_\_
2. Milk Tank During Milk Storage **Yes** \_\_\_\_\_ **No** \_\_\_\_\_

**J Initial Dynamic Test**

Performed **Yes** \_\_\_\_\_ **No** \_\_\_\_\_ **Date** \_\_\_\_\_

**A CLEANING PROGRAM INCLUDING WATER HARDNESS, DETERGENT AND SANITIZER  
MUST BE POSTED IN THE MILK ROOM**

The posted chart shall be legible and protected to provide a degree of permanency. If procedure is changed in any way, a new program must be posted.

**ANY FUTURE MODIFICATION OF THIS EQUIPMENT MUST HAVE PRIOR WRITTEN APPROVAL**

Owner or Authorized Representative: \_\_\_\_\_  
Signature

Installer/Dealer: \_\_\_\_\_  
Signature

\_\_\_\_\_  
Address

\_\_\_\_\_  
Phone Number

<b><u>OFFICIAL ACTION</u></b>		
1.	<b>Plan Approval</b>	
	Fieldman: _____ Signature	_____ Date
	Regional Sanitarian: _____ Signature	_____ Date
2.	<b>Installation Approval</b>	
	Regional Sanitarian: _____ Signature	_____ Date

**APPENDIX B**

**ASAE S518.2 DEC01**

**MILKING MACHINE INSTALLATIONS  
–CONSTRUCTION AND  
PERFORMANCE**

Reprinted with permission from the American Society of Agricultural Engineers, 2950  
Niles Rd., St. Joseph, MI 49085.

Contact the American Society of Agricultural Engineers for additional copies or a  
complete set of the ASAE Standards.

Telephone 269-429-0300 / 800-606-2304  
Fax 269-429-3852  
E-mail [martin@asae.org](mailto:martin@asae.org)  
Web site [www.asae.org](http://www.asae.org).

# Milking Machine Installations—Construction and Performance

*Proposed by the Milking Machine Manufacturers Council of the Equipment Manufacturers Institute; developed by ASAE IET 441 Milk Handling Equipment Committee; approved by the Electrical and Electronic Systems Division Standards Committee; adopted by ASAE January 1992; revised March 1994, July 1996; reaffirmed for one year December 2001.*

## 1 Purpose and scope

**1.1** This Standard specifies the minimum dimensional requirements for the satisfactory functioning of milking machines, including the minimum performance requirements for milking and cleaning. It also specifies requirements for construction and installation.

**1.2** This Standard applies to machines intended for milking cows or water buffaloes. The qualitative requirements also apply to machines for milking sheep and goats.

**1.3** This Standard is not expected to apply in every respect to installations with special design features which are (or may be) available; for example:

- bucket milkers;
- small mobile installations with an individual vacuum pump for each unit;
- independent air and milk transport milking machines;
- single-pipe pipeline milking installations;
- milking installations with double vacuum systems;
- milk extraction without pulsation;
- systems with compressed air pulsation or other special pulsation characteristics.

**1.4** This Standard does not address the relevant safety (mechanical and electrical) or hygiene requirements.

**1.5** This revision is based upon ISO/DIS 5707-1995, *Milking Machine Installations—Construction and Performance*, which was finalized and approved in October 1995.

## 2 Normative references

The following standards contain provisions which, through reference in this text, constitute provisions of this Standard. At the time of publication, the editions indicated were valid. All standards are subject to revision, and parties to agreements based on this Standard are encouraged to apply the most recent editions of the standards indicated below. Standards organizations maintain registers of currently valid standards.

- ANSI/ASAE S493 JUL93, *Guarding for Agricultural Equipment*  
 ANSI/ASME PTC 9-1974 (R1992), *Performance Test Code—Displacement Compressors, Vacuum Pumps and Blowers*  
 ASAE S300.2 JUL96, *Terminology for Milking Machines, Milk Cooling and Bulk Milk Handling Equipment*  
 ASAE EP445.1 JUL96, *Test Equipment and Its Application for Measuring Milking Machine Operating Characteristics*  
 IAMFES 3-A 63-00, *Sanitary Fittings for Milk and Milk Products*  
 IAMFES 3-A 606-03, *Accepted Practices for the Design, Fabrication and Installation of Milk Handling Equipment*  
 IAMFES 3-A 33-01, *Sanitary Standards for Polished Metal Tubing for Dairy Products*  
 IAMFES 3-A 2-08, *Sanitary Standards for Centrifugal and Positive Rotary Pumps for Milk and Milk Products*

IAMFES 3-A 18-01, *Multiple-use Rubber and Rubber-like Materials Used as Product Contact Surfaces in Dairy Equipment*

IAMFES 3-A 20-17, *Multiple-use Plastic Materials Used as Product Contact Surfaces in Dairy Equipment*

NFPA 70, *National Electrical Code*

## 3 Definitions

**3.1** For definitions, see ASAE S300.

**3.2** The word *shall* indicates a requirement for the installation to conform to this Standard, while the words *should* or *may* indicate a recommended practice.

## 4 General

**4.1 Tests for compliance.** Characteristics established by mechanical testing are based on the test(s) specified in ASAE EP445. Those tests shall be used for the purpose of verifying compliance with the requirements of this Standard.

**4.2 Access for measurements.** Some or all of the connection points identified below can be provided, if desired, by dismantling parts of the milking machine.

**4.2.1** To enable measurement of effective reserve, manual reserve, regulation loss, regulation efficiency (and regulator leakage, if desired), a connection point for an air flowmeter shall be provided at or near the receiver in pipeline milking machines, or at or near the sanitary trap in weigh jar machines.

**4.2.2** A connection point for an air flowmeter shall be provided at or near the vacuum pump(s) to enable measurement of pump capacity and system leakage.

**4.2.3** Additional connection points shall be provided for measuring vacuum level at or upstream of the receiver in pipeline milking machines, at or near the regulator sensing point, and near the vacuum pump inlet.

**4.3 Power failure.** Most milking machines depend on a public utility for electric power supply, which may occasionally fail. The user should provide a suitable arrangement for an alternative electric power supply for operating the machine in cases of emergency.

**4.4 Noise.** Equipment should be designed and installed so that noise levels in the barn or parlor, and in the vicinity, are as low as practicable.

**4.5 Safety.** All installations shall comply with the requirements for safety in national legislation, with NFPA 70 for grounding and wiring, and with the requirements of ANSI/ASAE S493.

## 5 Materials and fabrication

Materials and fabrication practices used shall comply with IAMFES 3-A 606-03, as amended.

## 6 Vacuum pumps

**6.1 Capacity.** The vacuum pump(s) shall have adequate capacity to meet the operating requirements for milking and for cleaning of the system, including all ancillary equipment operating during milking, whether continuously or intermittently. If more than one vacuum pump is installed, it shall be possible to isolate the pump(s) not in use.

NOTE—See guidelines for vacuum pump sizing in informative annex A.

**6.2 Effective reserve.** In addition to meeting the operating requirements in 6.1, the vacuum pump(s) shall have sufficient effective reserve capacity so that the vacuum drop in or near the receiver does not exceed 2 kPa (0.6 in. Hg) during the course of normal milking, including teatcup attachment and removal, liner slips, and cluster fall-off when tested in accordance with 11.1 in ASAE EP445.

Effective reserve capacity shall be determined in accordance with 7.1 in ASAE EP445.

**NOTES**

- 1 In most milking systems, this performance specification should be achieved by providing an effective reserve within the range 1000 to 3400 L/min (35 to 120 ft<sup>3</sup>/min). A simple formula for ensuring sufficient effective reserve is:
  - a base allowance of 1000 L/min (35 ft<sup>3</sup>/min)
  - plus an incremental allowance of 20 to 30 L/min (0.7 to 1 ft<sup>3</sup>/min) per unit.
- 2 Effective reserve should be increased to allow for vacuum-operated equipment that is not active during testing. The number of such components operating simultaneously should be taken into consideration. Ancillary equipment operated by a separate vacuum system need not be considered.

**6.3 Influence of altitude.** When vacuum pumps are operated at altitudes above sea level, vacuum pump sizing shall be adjusted using the values in table 1.

**6.4 Exhaust.** The exhaust from a lubricated vacuum pump shall not discharge into a room. The exhaust pipe should be as short as possible and should not obstruct the passage of the exhaust air by the use of inadequately sized piping or unnecessary fittings. If possible, the exhaust pipe shall have a continuous slope away from the vacuum pump. If this cannot be achieved, a suitable moisture trap, with provision for drainage, shall be fitted. For lubricated vane-type pumps, it is recommended that an oil separator be fitted to the exhaust pipe.

**6.5 Prevention of reverse rotation.** The vacuum pump should be equipped with a non-return valve (check valve). If not, then a tap (cock) for admitting atmospheric air to the vacuum system shall be provided adjacent to the vacuum pump control switch.

**6.6 Location.** The vacuum pump shall be located so the pump speed can readily be measured. It shall be connected so the vacuum pump capacity can be measured in accordance with 8.2 in ASAE EP445. It should be located near the milking barn, stable, or parlor in a relatively clean and dry place.

**6.7 Marking.** The vacuum pump assembly shall be marked with the following information in indelible lettering:

- name of the manufacturer or supplier;
- type and identification (eg, model and serial number or code);
- the direction of rotation;

- the range of speed, rpm, and power requirement in kilowatts or horsepower;
- the corresponding range of extraction capacity at 50 kPa (15 in. Hg), expressed as free air at sea level, in L/min (ft<sup>3</sup>/min) (see ANSI/ASME PTC 9);
- recommended lubricants and equivalents.

**7 Vacuum regulation**

**7.1 Marking and specification**

**7.1.1** The regulator shall be marked with the following information in indelible lettering:

- name of the manufacturer or supplier;
- model;
- designed working vacuum range in kPa and in. Hg;
- airflow capacity at 50 kPa (15 in. Hg), expressed as free air at sea level, in L/min and ft<sup>3</sup>/min.

**7.1.2** The regulator leakage, expressed in L/min and ft<sup>3</sup>/min, at the upper and lower ends of the designed working range when the regulator is nominally closed, shall be stated by the manufacturer (see 7.3 in ASAE EP445 for test procedure, and 10.8 in ASAE S300 for definition).

**7.2 Mounting**

**7.2.1** The regulator shall be mounted according to manufacturer's specifications to be as free from vibration as possible and positioned so moisture from the airlines cannot enter the regulator. The regulator should be mounted in a clean and readily accessible location. The vacuum sensor or regulator should be connected to the main airline as near to the sanitary trap as practicable.

**NOTES**

- 1 Only sensors designed so that they fulfill all hygiene requirements may be placed at the sanitary trap, or the receiver, or between them.
- 2 A long branch line for the regulator is acceptable provided that the line diameter is sufficient to ensure that regulation loss is less than 10%.

**7.2.2** Unless specifically required by the manufacturer, the vacuum sensor shall not be mounted:

- between the vacuum pump and distribution tank;
- into the milkline or milk receiver;
- into the pulsator airline

**7.3 Performance**

**7.3.1 Cluster fall-off.** The mean equilibrium vacuum in the receiver should not fall more than 2 kPa (0.6 in. Hg) below the normal working vacuum when tested in accordance with 6.3 in ASAE EP445 with:

- one milking unit held fully open to admit air into systems with up to 32 units;
- two milking units held open in systems with more than 32 units.

**NOTE**—An initial, transient vacuum drop greater than 2 kPa (0.6 in. Hg) may indicate regulator undershoot. The subsequent equilibrium vacuum indicates the combined effects of the sensitivity and state of cleanliness of the vacuum regulator, the amount of manual reserve, and the head loss due to air flow in the connecting pipes and fittings.

**7.3.2 Regulation loss.** The total "unplanned" air leakage through the regulator when tested according to 7.2 in ASAE EP445 shall not exceed 10% of the manual reserve, at a vacuum level of 2 kPa (0.6 in. Hg) below the working vacuum.

**NOTE** – This implies that the regulation efficiency shall be at least 90%. That is, the effective reserve shall be at least 90% of the manual reserve.

**Table 1 – Elevation correction factors for vacuum pump rating**

Elevation (above sea level)		Correction factor <sup>1)</sup>
m	ft	
0	0	1.00
300	1000	0.96
600	2000	0.93
900	3000	0.90
1200	4000	0.87
1500	5000	0.83
1800	6000	0.80
2100	7000	0.77
2400	8000	0.74

<sup>1)</sup>Correction factor times capacity at sea level equals true capacity at elevation.

## 8 Vacuum gauges

**8.1 Accuracy.** When a gauge is mounted and calibrated, the error measured according to 6.1 in ASAE EP445 shall not exceed 1 kPa (0.3 in. Hg) at the working vacuum level.

**8.2** A gauge shall be mounted where it is readable during milking and should be visible from near the regulator.

NOTE – A vacuum gauge should be readable from the place where the milking machine is started. More than one vacuum gauge may be needed.

## 9 Airlines (vacuum pipelines)

**9.1** The main airline(s) shall be of sufficient size to ensure a drop of not more than 2 kPa (0.6 in. Hg) from the vacuum pump to any point in the vacuum system when tested as per 6.2 in ASAE EP445

NOTE—See guidelines for sizing in informative annex B.

**9.1.1** Pulsator airlines shall not be smaller than manufacturer's recommendations, and should not be smaller than the diameter shown in table 2.

## 10 Drain valves

Provision shall be made for complete drainage of all milk and cleaning solution contact surfaces, when the vacuum is shut off. In all cases, drain valves shall be accessible.

## 11 Distribution tank, sanitary trap, and interceptor

**11.1 Distribution tank.** The distribution tank, if used, should be mounted in an accessible position. It shall be provided with automatic drainage facilities such that the effluent discharges to a safe and convenient location.

**11.2 Sanitary trap.** The sanitary trap shall comply with the appropriate section of IAMFES 3-A 606-03 as amended.

**11.3 Interceptor.** An interceptor may be fitted between the vacuum pump and the vacuum regulator. There shall be no intermediate connections into the airline between the interceptor and the pump, except as required for test purposes or connection of a safety valve. The interceptor shall incorporate a liquid-level operated vacuum shut-off and shall be provided with automatic drainage facilities. The internal diameter of the inlet and outlet of the interceptor should be not less than that of the air lines connected to it.

## 12 Stall-cocks

Stall-cocks shall be connected to the upper part of the pulsator airline. They should be firmly fixed to the airline to prevent displacement in relation to the pipeline orifices. Gaskets should not obstruct the stall-cock aperture. Stall-cocks should have stops at the fully open and fully closed positions, and they should be airtight when closed.

## 13 Pulsation systems

**13.1 Performance data.** The pulsation rate, pulsator ratio, and pulsator phases shall be measured according to clause 10 in ASAE EP445. The following data shall be provided:

- the pulsation rate at a nominal vacuum and temperature;
- the temperature range over which pulsators can be used;
- the variation of pulsation rate within this range;
- typical pulsation curves for a defined cluster or test apparatus with a specified volume;
- air consumption with defined cluster.

**13.2 Pulsation rate.** During test conditions, the pulsator rate shall not deviate more than  $\pm 3$  cycles/min from the values provided by the installer.

**13.3 Pulsator ratio.** During test conditions, the pulsator ratio shall not differ more than  $\pm 5$  units of percentage from the values stated by the manufacturer. Within a cluster, no two teatcups may vary from each other by more than 5 units of percentage except where the cluster is designed to provide differing ratios between the front and hind quarters.

**13.4 Pulsator phases (see figure 3 in ASAE S300).** Phase *b* shall be not less than 30%. Phase *d* shall be not less than 15% and not less than 150 ms. Vacuum variations during phases *b* and *d* shall not exceed 4 kPa (1.2 in. Hg).

NOTE—Wiring for electrically operated pulsators should be sufficient so that voltage drop will not impair pulsator function.

## 14 Design of milkline systems

**14.1** Milklines should be designed so that stratified flow is the normal condition during milking. Stratified flow occurs when milk flows in the lower part of the milkline and air flows in a clear, continuous path above the milk. A milkline having a maximum vacuum drop of 2 kPa (0.6 in. Hg) from the receiver to any point in the milkline, under normal milking conditions, is considered to have stratified flow (see test method in clauses 11.2 of ASAE EP445). The normal flow condition means slug free conditions for at least 95% of the milking time. Occasional slugs in the milkline, which are almost unavoidable in practice, should not be regarded as evidence of an improperly designed system.

**14.2 Milkline slope.** A slope is a length of milkline having a continuous downward gradient toward the receiver. Milklines shall have a continuous gradient towards the receiver, with a minimum gradient of 0.8% (8 mm per meter, or 1 in. per 10 ft).

NOTE—Where practicable, milkline slope may be increased slightly near the receiver end of the milkline to compensate for the effects of bends or other fittings.

**14.3** Where practicable, the milkline shall form a loop, the ends of which shall have separate full-bore connections to the receiver.

NOTE—The number of milking units that should be used on a milkline depends largely upon its diameter and slope. Guidelines are given in informative annex C for the recommended maximum number of units per slope that should be used to maintain stratified flow.

## 15 Milkline and fittings

**15.1 Leakage.** Air leakage into the milklines, meters, weigh jars, receiver, and the fittings shall not exceed 20 L/min (0.7 ft<sup>3</sup>/min) plus an additional maximum of 2 L/min (0.07 ft<sup>3</sup>/min) per unit.

**15.2 Drainage.** Provision shall be made for complete drainage of all parts of the milk system when vacuum is shut off.

**15.3 Milk cocks and milk inlets.** Milk cocks and milk inlets shall be positioned so the entry is above the centerline of the pipeline. They shall be easy to clean and disinfect. They shall have stops at the fully open and fully closed positions, and have closures that are readily applied and of sanitary design.

**15.4 Tubing and fittings.** Tubing and fittings shall be per IAMFES 3-A 33-01, as amended, per 3-A 606-03, as amended, and IAMFES per 3-A 63-00, as amended. Provision shall be made for inspection of the inside of the pipeline.

Table 2 – Recommended minimum sizes for looped pulsator airlines

Number of units	Pipe diameter <sup>1)</sup>
1 to 14	50 mm (2 in.)
15 or more	75 mm (3 in.)

<sup>1)</sup>Metric=nominal ID. Inch=US pipe size.

## 16 Weigh jars (recorder jars)

**16.1 General.** Weigh jars shall have an effective volume of not less than 23 kg (50 lb) or 23 L (0.8 ft<sup>3</sup>) and incorporate a method of measurement.

**16.2** Weigh jars shall be suitable for in-place washing and capable of withstanding a differential pressure of not less than 100 kPa (29.5 in. Hg). They shall have connections that are located to minimize the risk of carry-over of milk or foam into the vacuum system.

**16.3** Weigh jars shall have an outlet of not less than 11 mm (0.43 in.) internal diameter.

**16.4 Mounting.** The jars should be rigidly fixed and set to ensure the greatest accuracy of calibration. The jars shall be fixed so that the scale can be easily read by the operator. Means shall be provided to prevent flattening of the milk hose due to direct pull or constant drag on the inlet nipple of the weigh jar.

## 17 Ancillary components of the milking unit

Devices, including necessary connecting tubes, fitted in a long milk tube shall not cause an additional vacuum drop of more than 5 kPa (1.5 in. Hg) measured in the cluster (at a milk flow rate of 5 kg/min (11 lb/min) and an airflow of 8 L/min (0.3 ft<sup>3</sup>/min)), compared with the same milking unit without those devices, when measured in accordance with annex A in ASAE EP445. Milk meters used at every milking shall comply with this requirement. Those used periodically for milk recording should also comply with this requirement.

## 18 Flexible tubes

**18.1 Short milk tubes.** The internal diameter of short milk tubes shall not be less than 9 mm (0.35 in.) along their full length when the tubes are in the milking position.

**18.2 Milk hoses.** The internal diameter of the milk hose for single-outlet milk claws shall not be less than 14 mm (0.56 in.). Milk hoses should be as short as practicable and shall not exceed 2.7 m (9 ft) in length.

**18.3 Long pulse tubes (air tubes).** The internal diameter of long pulse tubes shall not be less than 7 mm (0.28 in.) except in the case of installations with alternating pulsation, where the internal diameter shall not be less than 6 mm (0.24 in.).

**18.4 Short pulse tubes (air tubes).** The internal diameter of short pulse tubes shall not be less than 5 mm (0.20 in.).

## 19 Cluster assemblies

**19.1 Internal dimensions of teatcup shell.** The internal dimensions of the shell shall not restrict the operation of the liner. The liner and shell combination shall provide a means to indicate if the liner is twisted or means to prevent the liner from twisting in the shell.

**19.2 Claw.** A means shall be provided to shut off the milking vacuum for cluster removal. Air leakage through the vacuum shut-off valve when closed shall not exceed 2 L/min (0.07 ft<sup>3</sup>/min).

NOTE – Means should also be provided to limit the airflow through the cluster during attachment.

## 20 Receivers

The receiver shall be capable of withstanding a differential pressure of not less than 100 kPa (29.5 in. Hg). It shall be suitable for in-place cleaning. Gaskets shall be designed for easy cleaning, and they shall be easy to remove.

## 21 Releasers

**21.1** A releaser, if fitted into the installation, shall be adequate to handle the maximum rate at which milk, cleaning, and sanitizing solutions are released into the system. The releaser should be capable of discharging the milk without undue formation of foam.

**21.2 Pneumatic releasers.** Data on air consumption of pneumatic releasers at the maximum milk flow rate shall be provided.

**21.3 Centrifugal or positive rotary pumps.** Milk pumps shall comply with IAMFES 3-A 02-08, as amended. The operation of a centrifugal or positive rotary milk pump shall be controlled by the quantity of milk in the receiver.

## 22 In-place cleaning and disinfection

**22.1** Installations designed for in-place cleaning and disinfection shall be constructed so all milk contact surfaces are capable of being effectively cleaned and disinfected. Attachments such as filters, mastitis detectors or indicators, surface coolers, and ancillary equipment not specifically designed for circulation cleaning and disinfection should be removed for separate cleaning and disinfection.

### 22.2 Pre-cooling

**22.2.1** Where in-line cooling equipment is fitted, means, preferably automatic, shall be provided to stop the flow of coolant during the washing cycle.

**22.2.2** In-line coolers shall be installed with appropriate ancillary equipment so that they can be cleaned-in-place without impairing the effectiveness of cleaning the rest of the system.

## 23 Instructions for use and maintenance

**23.1** Full written instructions shall be provided for operating, cleaning, and sanitizing the installation (including the temperature range at which the installation should be cleaned and sanitized and the cleaning chemicals recommended). Written instructions for routine servicing including replacement of individual parts shall be provided, together with all manuals supplied by the equipment manufacturer.

**23.2** The results of a post-installation test and system evaluation as outlined in ASAE EP445 shall be provided.

**23.3** Instructions should be readily available to the operator.

## Annex A (informative)

### Guidelines for vacuum pump sizing

#### A1 Vacuum pump capacity for milking

The recommended pump capacity for new installations is based on the following allowances.

1000 L/min (35 ft<sup>3</sup>/min) for the basic effective reserve.

An additional 60 to 70 L/min (2 to 2.5 ft<sup>3</sup>/min) for each milking unit, to cover:

- 20 to 30 L/min (0.7 to 1 ft<sup>3</sup>/min) per milking unit for the incremental component of effective reserve;

- pulsator consumption of 30 L/min (about 1 ft<sup>3</sup>/min) per unit;
- claw air admission of 10 L/min (0.35 ft<sup>3</sup>/min) per unit;

Air leaks, frictional losses, and pump wear. To allow for all of these contingencies, the calculated airflow requirements should be multiplied by a factor of 1.2 to 1.3, to cover:

- system leakage	5 to 10% of pump capacity
- regulation loss	5% of pump capacity (5 to 10% of the manual reserve)
- frictional losses	3% of pump capacity (2 kPa drop from pump to receiver)
- pump wear	5 to 10% of pump capacity

---

Total	18 to 28%, which is approx 1.2 to 1.3.
-------	--

In well-designed systems with low air leakage, low frictional losses and correct regulator location, an extra 20% (that is, a factor of 1.2) is more than adequate. Therefore, the recommended **basic** pump capacity=

$$(1000 + 1.2 \times 70n) \text{ L/min} = (1000 + 85n) \text{ L/min}$$

or

$$(35 + 1.2 \times 2.5n) \text{ ft}^3/\text{min} = (35 + 3n) \text{ ft}^3/\text{min}$$

where

$n$  is the number of milking units.

The vacuum pump(s) and motor(s) should be selected to provide at least the basic pump capacity at the normal operating vacuum for the system (which is not necessarily 50 kPa, or 15 in. Hg).

### A2 Additions to the basic pump capacity for milking

There may be other additions to the basic pump capacity for particular systems, to cover:

- “air lubricated” regulators, which require an extra 200 to 800 L/min (7 to 28 ft<sup>3</sup>/min);
- some types of milk meters with an air vent (up to 15 L/min, 0.5 ft<sup>3</sup>/min, per meter);
- milk sweeps, and air sweeps for some back-flush systems (check manufacturer’s specifications);
- an extra allowance, perhaps, for cleaning (see following section A3).

### A3 Vacuum pump capacity for air-injected CIP cleaning systems

With proper system design and control of air and liquid flowrates, the vacuum pump capacity required for efficient cleaning is less than that required for efficient milking. Most milking systems will have sufficient vacuum pump capacity for air-injected CIP washing if sized according to the following relationship:

$$\text{Vacuum pump capacity for cleaning} = Q_c + (n \times Q_s)$$

where:

$Q_c$  is flowrate of cycled air admission (L/min or ft<sup>3</sup>/min from table A3) to produce a slug velocity of 7 m/s (23 ft/s) in each milkline loop;

$n$  is the number of milking units;

**Table A3 – Air injection rate to produce slug speeds of 7 m/s (23 ft/s)**

Milkline diameter (nominal ID)	Air flowrate
48mm(2in.)	390 L/min (14 ft <sup>3</sup> /min)
60mm(2.5in.)	570 L/min (20 ft <sup>3</sup> /min)
73mm(3in.)	790 L/min (28 ft <sup>3</sup> /min)
98mm(4in.)	1300 L/min (49 ft <sup>3</sup> /min)

$Q_s$  is steady air usage of 60 L/min (2 ft<sup>3</sup>/min) per milking unit to cover pulsator consumption, cluster air vents, system leakage and regulation loss.

The minimum air requirement for cleaning is when only one air injector is open at any one time. For example, a double-12 parlor with one 3 in. milkline loop would need a minimum vacuum pump capacity of:

$$(28) + (24 \times 2) = 76 \text{ ft}^3/\text{min} \text{ for cleaning,}$$

compared with

$$35 + (24 \times 3) = 107 \text{ ft}^3/\text{min} \text{ for milking.}$$

The median air requirement is when two flow circuits each receive cycled air-injection simultaneously, plus the basic incremental allowance of 60 L/min (2 ft<sup>3</sup>/min) per unit. For example, a double-24 parlor with two 3 in. milkline loops would need a minimum vacuum pump capacity of:

$$(2 \times 28) + (48 \times 2) = 152 \text{ ft}^3/\text{min} \text{ for cleaning,}$$

compared with

$$35 + (48 \times 3) = 179 \text{ ft}^3/\text{min} \text{ for milking.}$$

The maximum air requirement for cleaning would be when two air injectors are open at any one time, and the incremental allowance ( $Q_s$ ) has to be increased from 60 up to 95 L/min (from 2 up to 3.3 ft<sup>3</sup>/min) per unit to cover the extra air vent in some types of jettors. Such a system might require an extra vacuum pump for washing unless the two air injectors are sequenced so that only one is open at any time. Using the example of a double-24 parlor with two 3 in. milkline loops, the minimum vacuum pump capacity for cleaning would be:

$$(2 \times 28) + (48 \times 3.3) = 214 \text{ ft}^3/\text{min} \text{ without sequenced air injection}$$

compared with

$$28 + (48 \times 3.3) = 186 \text{ ft}^3/\text{min} \text{ with sequenced air injection.}$$

**Annex B**  
(informative)  
**Recommended minimum sizes (mm or inches internal diameter) for main airlines**

Vacuum pump capacity L/min free air	Approx. length of main airline (m of straight pipe)			
	5	15	20	25
1500	50 mm	75	75	75
2000	75	75	75	5
3000	75	75	75	100
4000	100	100	100	100
5500	100	100	100	100
7000	100	150	150	150
8500	150	150	150	150
10000	150	150	150	150

Vacuum pump capacity ft <sup>3</sup> /min free air	Approx. length of main airline (feet of straight pipe)						
	10	20	40	60	80	100	200
50	2 in.	2	3	3	3	3	3
70	3	3	3	3	3	3	3
100	3	3	3	3	4	4	4
150	4	4	4	4	4	4	4
200	4	4	4	4	4	4/6	6
250	4	4	6	6	6	6	6
300	6	6	6	6	6	6	6
400	6	6	6	6	6	6	6

NOTE – The main airline is defined as the pipeline between the vacuum pump and the sanitary trap near the receiver. These calculations are based on a maximum vacuum drop of 2 kPa (0.6 in. Hg) between the vacuum pump and receiver. The maximum air flowrate is normally from the vacuum regulator to the pump. Whenever additional air enters the milking clusters during milking, however, the maximum air flowrate is from the receiver to the vacuum pump.

These tables include an allowance for the equivalent length (m or feet of straight pipe) of one distribution tank, one sanitary trap, and eight elbows. If the system includes more than eight elbows, then use in the next pipe length column to the right for every three additional elbows.

In systems with two receivers, the theoretical maximum air flowrate in the two separate airlines between the distribution tank and the sanitary traps may be halved. The size of these split lines can be reduced according to the values in the table corresponding to half the vacuum pump capacity.

**Annex C**  
(informative)  
**Design guidelines and recommendations for maximum number of units per milking slope to assume stratified flow**

These guidelines are based on the fastest-milking 5% of cows in the US and France, ie, a mean peak milking rate of 5.5 L/min (12 lb/min) per cow.

Steady air admission within the range 10 to 20 L/min (0.35 to 0.7 ft<sup>3</sup>/min) per unit through claw air vents and air leaks is assumed in the calculations.

The guidelines assume that the cross-sectional area of the milking line(s) is not substantially reduced by fittings.

A slope of 0.8% is equivalent to 8 mm drop per m of run (1 in. drop in 10ft).

A slope of 1.2% is equivalent to 12 mm drop per m of run (1.5 in. drop in 10 ft).

**Table C1 – Milking parlors: looped milking line with units attached simultaneously by careful operators. Transient air admission of 100 L/min (3.5 ft<sup>3</sup>/min) per milking slope**

Nominal milking line size	Maximum number of units per slope				
	0.8%	1.0%	1.2%	1.5%	2.0%
48 mm (2 in.)	2	3	3	4	5
60 mm (2.5 in.)	6	6	7	9	10
73 mm (3 in.)	11	13	14	16	19
98 mm (4 in.)	27	30	34	38	45

**Table C2 – Milking parlors: looped milking line with units attached simultaneously by typical operators. Transient air admission of 200 L/min (7 ft<sup>3</sup>/min) per milking slope**

Nominal milking line size	Maximum number of units per slope				
	0.8%	1.0%	1.2%	1.5%	2.0%
48 mm (2 in.)	1	1	2	2	3
60 mm (2.5 in.)	4	4	5	6	8
73 mm (3 in.)	9	10	12	13	16
98 mm (4 in.)	24	27	31	36	41

**Table C3 – Stanchion barns: looped milking lines with units attached every 30 seconds per slope. Transient air admission of 100 L/min (3.5 ft<sup>3</sup>/min) per milking slope**

Nominal milking line size	Maximum number of units per slope			
	0.8%	1.0%	1.2%	1.5%
48 mm (2 in.)	2	3	3	4
60 mm (2.5 in.)	6	9	*(9)	*(9)
73 mm (3 in.)	*(9)	*(11)	*(13)	*(16)

NOTE – Asterisk indicates an unlimited number of units when they are attached at 30 s intervals. If more than one operator is attaching units on the same slope, the attachment rate may be quicker than one unit every 30 s. If so, then the guideline figures in table C could be used.

# APPENDIX C

## ASAE EP445.1 DEC 01

### TEST EQUIPMENT AND ITS APPLICATION FOR MEASURING MILKING MACHINE OPERATING CHARACTERISTICS

Reprinted with permission from the American Society of Agricultural Engineers, 2950 Niles Rd., St. Joseph, MI 49085.

Contact the American Society of Agricultural Engineers for additional copies or a complete set of the ASAE Standards.

Telephone 269-429-0300 / 800-606-2304

Fax 269-429-3852

E-mail [martin@asae.org](mailto:martin@asae.org)

Web site [www.asae.org](http://www.asae.org)

# Test Equipment and Its Application for Measuring Milking Machine Operating Characteristics

*Proposed by the Milking Machine Manufacturers Council of the Equipment Manufacturers Institute in conjunction with the ASAE IET 441 Milk Handling Equipment Committee; approved by the Electrical Power and Processing Division Standards Committee; adopted by ASAE March 1985; reconfirmed for one year December 1989; revised July 1996; reaffirmed for one year December 2001.*

## 1 Purpose and scope

**1.1** This Engineering Practice specifies mechanical tests for milking installations in order to verify compliance of an installation or component with the requirements of ASAE S518. It also stipulates the accuracy requirements for the measuring instruments.

**1.2** This Engineering Practice is applicable for testing new installations and for periodic checking of installations for efficiency of operation.

**1.3** This revision is based upon ISO/DIS 6690-1995, Milking Machine Installations—Mechanical Tests, and the US National Mastitis Council (NMC 1996) Procedures for Evaluating Vacuum Levels and Air Flow in Milking Systems.

## 2 Normative references

The following standards contain provisions which, through reference in this text, constitute provisions of this Standard. At the time of publication, the editions indicated were valid. All standards are subject to revision, and parties to agreement based on this Standard are encouraged to apply the most recent editions of the standards indicated below. Standards organizations maintain registers of currently valid standards.

- ASAE S300.3 JUL96, *Terminology for Milking Machines, Milk Cooling, and Bulk Milk Handling*
- ASAE S518.2 JUL96, *Milking Machine Installations—Construction and Performance*

## 3 Definitions

For definitions, see ASAE S300.

## 4 Test equipment and specifications

Measuring equipment shall have a precision that ensures that requirements given in ASAE S518 can be recorded with the stated accuracy. The instruments shall be checked regularly to ensure compliance with the given specifications. They should be rugged and portable.

### 4.1 Measurement of vacuum level

Vacuum gauges shall have a range of 0 to 100 kPa (0 to 30 in. Hg). Test gauges used for on-farm measurements shall have an accuracy of  $\pm 1$  kPa (0.3 in. Hg), and calibration-type gauges shall have an accuracy of  $\pm 0.5$  kPa (0.15 in. Hg).

### 4.2 Measurement of vacuum changes

**4.2.1** Vacuum recorders shall have a minimum operating range of 0 to 51 kPa (0 to 15 in. Hg) and shall withstand up to 68 kPa (20 in. Hg) without damage to the recorder. Recorders shall be able to indicate vacuum levels with an accuracy of  $\pm 1.5$  kPa (0.45 in. Hg), and vacuum changes with an accuracy of  $\pm 0.5$  kPa (0.15 in. Hg).

**4.2.2** The vacuum recording system (that is, an analog or digital vacuum recorder with its connecting tubes and fittings) should have a response rate of at least 500 kPa/s (150 in.Hg/s).

NOTE – Response rate can be calculated easily by connecting the recording system directly to a pulsator (see figure 1) and recording the “a-phase” of the cyclic vacuum change (see figure 3 of ASAE S300). If the system vacuum level was 45 kPa, for example, then the a-phase is calculated as the time taken to respond to an abrupt change in input vacuum from 4 kPa to 41 kPa. If the a-phase was 50 ms, then the response rate of the recording system would be:

$$(45 - 4 - 4) \times 1000 / 50 = 740 \text{ kPa/s}$$

**4.2.3** The vacuum recorder shall have a sampling rate of at least 16 Hz. A sampling rate of at least 64 Hz is preferred.

NOTE – At 16 Hz, the preferred response rate of the vacuum recording system should be at least 1000 kPa/s (300 in. Hg/s). This implies the use of a T-piece, rather than a 12- or 14-gauge hypodermic needle, for connection to the milking machine.

### 4.3 Measurement of pulsation characteristics

**4.3.1** The instrument should have an operating range of 40 to 80 pulsation cycles/min and a minimum operating vacuum range of 0 to 51 kPa (0 to 15 in. Hg). Equipment shall withstand up to 68 kPa (20 in. Hg) without damage to the recorder.

**4.3.2** The instrument used, including connecting tubes, shall have an accuracy of  $\pm 1$  cycle/min for measuring pulsation rate and an accuracy of  $\pm 2\%$  for measuring the pulsation phases and the pulsation ratio.

### 4.4 Measurement of air flow

**4.4.1** The instrument used shall be capable of measuring with a maximum error of 5% of the measured value over a vacuum range of 30 to 60 kPa (8.9 to 17.8 in. Hg).

**4.4.2** A fixed-orifice flowmeter is suitable for measuring air flows admitted from atmosphere such as effective reserve, manual reserve, system leakage, and vacuum pump capacities. A variable-area

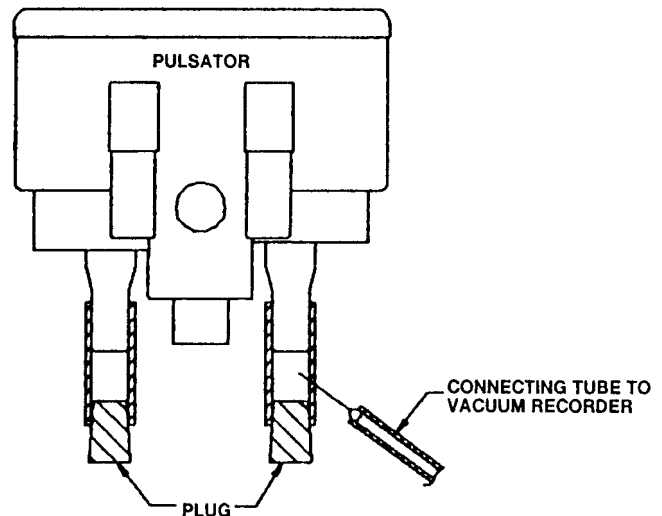

Figure 1 – Connection for measuring the response rate of vacuum recording systems

flowmeter, inserted in the milk hose, is suitable for measuring air admission and air leakage into individual clusters.

NOTE – Air flowmeter readings should be corrected for vacuum level and the ambient atmospheric pressure according to instructions from the manufacturer. See additional guidelines in annex C2.

#### 4.5 Measurement of pump speed

The instrument used shall be suitable for measuring the frequency of rotation ( $\text{min}^{-1}$ ) with an accuracy of  $\pm 3\%$  of the measured value.

#### 4.6 Measurement of atmospheric pressure

The instrument used shall be capable of measuring the atmospheric pressure with an accuracy of at least  $\pm 1 \text{ kPa}$  (0.3 in. Hg).

#### 4.7 Teatcup plugs

Standard teatcup plugs, as shown in figure 4 of ASAE S300, should be used. The plugs shall withstand cleaning and disinfection and shall be suitable for use in contact with milk.

#### 4.8 Instruction manuals

Manuals should be provided with the measuring equipment and contain complete specifications as well as specific information on the proper use, calibration, care, cleaning, and storage of the equipment.

### 5 Milking system test preparation

5.1 A visual check should be made to determine that the equipment is in good running order and that all controls are set per manufacturers recommendations. Safety checks should be performed (see ASAE S518, 4.5).

5.2 Start the vacuum pump and put the milking machine into the milking position with all milking units connected. The milking system shall be run for a minimum of 10 min or until operating characteristics stabilize before taking measurements.

5.3 Teatcup plugs shall be fitted and all controls (e.g., automatic cluster remover systems) shall be in the milking position. All vacuum-operated equipment associated with the installation shall be connected including that not operating during milking.

5.4 Record atmospheric pressure.

5.5 Guidelines are given in annexes B and C for connection of test meters.

### 6 System vacuum levels and differences

#### 6.1 Accuracy of farm vacuum gauge (see ASAE S518, 8.1)

6.1.1 With the milking machine operating as in 5.3, connect the test gauge to a test port close to the permanently mounted vacuum gauge and measure the vacuum level.

6.1.2 Calculate and record the *gauge error* as the difference between the vacuum level recorded in 6.1.1 and the reading from the permanently mounted gauge.

#### 6.2 Vacuum drop in airlines (see ASAE S518, 9.1)

6.2.1 With the milking machine operating as in 5.3, connect the test gauge to a test port close to the vacuum pump inlet and measure the pump working vacuum level (figure 2).

6.2.2 Measure working vacuum at the regulator (or its sensor), in the pulsator airline furthest from the vacuum source, and at or near the receiver. In weigh jar systems, measure the working vacuum in the vacuum supply hose to the first weigh jar (figure 3).

6.2.3 Calculate and record the *vacuum drop* as the differences between the vacuum level measured in 6.2.1 and all vacuum levels measured in 6.2.2.

#### 6.3 Cluster fall-off test (see ASAE S518, 7.3.1)

6.3.1 With the milking machine operating as in 5.3, connect the test gauge at or near the receiver (or vacuum supply hose to the first weigh jar in weigh jar systems) and measure the working vacuum.

6.3.2 Open one milking unit and hang it upside down to simulate a unit

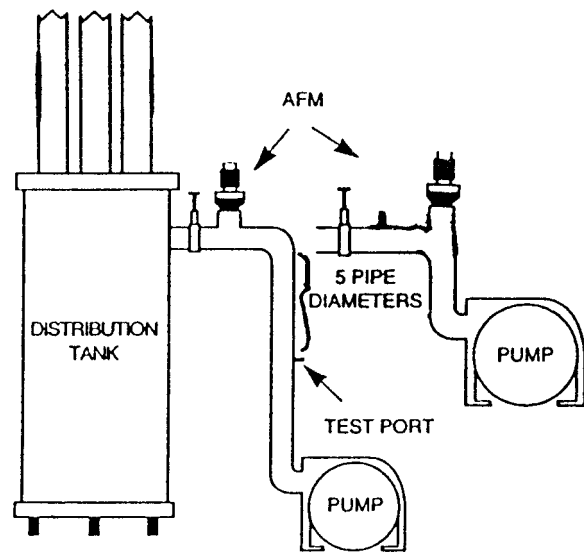

Figure 2 – Pump inlet vacuum

fall and record the vacuum reading on the test gauge. For systems with more than 32 units, open two units and repeat this measurement.

#### NOTES

1 To minimize measurement errors due to high air speeds, avoid opening a milking unit on the same milkline slope where working vacuum is measured.

2 For systems with two receivers and 32 units or less, this measurement should be carried out by opening one milking unit for one receiver. Record the result. Close the first unit, then open one unit on the other receiver and record the result. For systems with more than 32 units per receiver, open two units on one receiver and record the result. Close the first two units, then open two units on the other receiver and record the result.

6.3.3 Calculate and record the *vacuum differences* between the vacuum level at the receiver (or vacuum supply hose to the first weigh jar in weigh jar systems) measured in 6.3.1 and all vacuum levels measured in 6.3.2.

### 7 Air flow tests at receiver (or at sanitary trap in weigh jar milking machines)

#### 7.1 Effective reserve (see ASAE S518, 6.2)

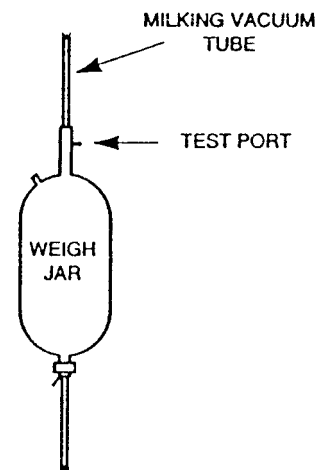

Figure 3 – Measurement of vacuum drop in weigh jar systems

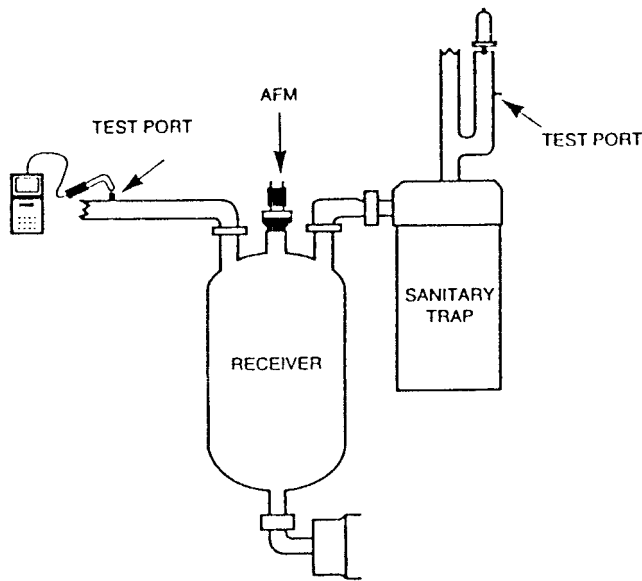

Figure 4 – Connection of air flowmeter

7.1.1 With the milking machine operating as in 5.3, connect an air flowmeter at or near the receiver on pipeline systems (figures 4 and 5) or to the vacuum supply line for weigh jar systems.

7.1.2 Open the air flowmeter until the working vacuum drops 2 kPa (0.6 in. Hg) at or near the receiver for pipeline systems. In recorder jar systems, measure this change in working vacuum in the vacuum supply hose to the first weigh jar, preferably on the opposite side of the parlor from the air flowmeter connection point.

7.1.3 Record the air flowmeter reading as the *effective reserve*.

**7.2 Regulation loss and regulation efficiency (see ASAE S518, 7.3.2)**

7.2.1 Determine effective reserve as detailed in 7.1.

7.2.2 Disable the regulator.

NOTE – Most servo-regulators can be put out of operation by disconnecting the vacuum sensing tube and taping or plugging the vacuum connection to the airline. Regulators designed to use air for “lubrication” can be put out of operation by removing the filter on top of the dome and taping the small air vent closed underneath this filter. When any of these types of regulators are disabled in this way, the resulting measurement gives the true manual reserve.

7.2.3 Readjust the air flowmeter until the working vacuum drops 2 kPa (0.6 in. Hg) at or near the receiver for pipeline systems (or vacuum supply hose to the first weigh jar in weigh jar systems).

7.2.4 Record the air flowmeter reading as the *manual reserve*.

7.2.5 Calculate and record the *regulation loss* as the difference between the manual reserve and the effective reserve measured in 7.1.

7.2.6 Calculate and record the *regulation efficiency* as the effective reserve (ER) expressed as a percentage of the manual reserve (MR):

$$100 \times ER/MR \text{ percent.}$$

**7.3 Regulator leakage (see ASAE S518, 7.1.2)**

7.3.1 With the milking machine operating as in 5.3, connect an air flowmeter at or near the receiver on pipeline systems (figures 4 and 5) or to the vacuum supply line for weigh jar systems, or near the regulator if there is a convenient connection point for the test.

7.3.2 Connect the test vacuum gauge to a test port at or near the regulator sensing point and record the vacuum level as the *regulator working vacuum* (or regulator set-point).

7.3.3 Open the air flowmeter until the regulator working vacuum drops 2 kPa (0.6 in. Hg).

7.3.4 Record the air flowmeter reading.

7.3.5 Disconnect the regulator and plug the connection.

7.3.6 Readjust the air flowmeter until the regulator working vacuum drops 2 kPa (0.6 in. Hg) below the level measured in 7.3.2 and record the air flowmeter reading.

7.3.7 Calculate and record the *regulator leakage* as the difference between the air flows recorded in 7.3.6 and 7.3.4.

**8 Air flow tests at or near vacuum pump**

**8.1 Air leakage into milking line and fittings (see ASAE S518, 15.1)**

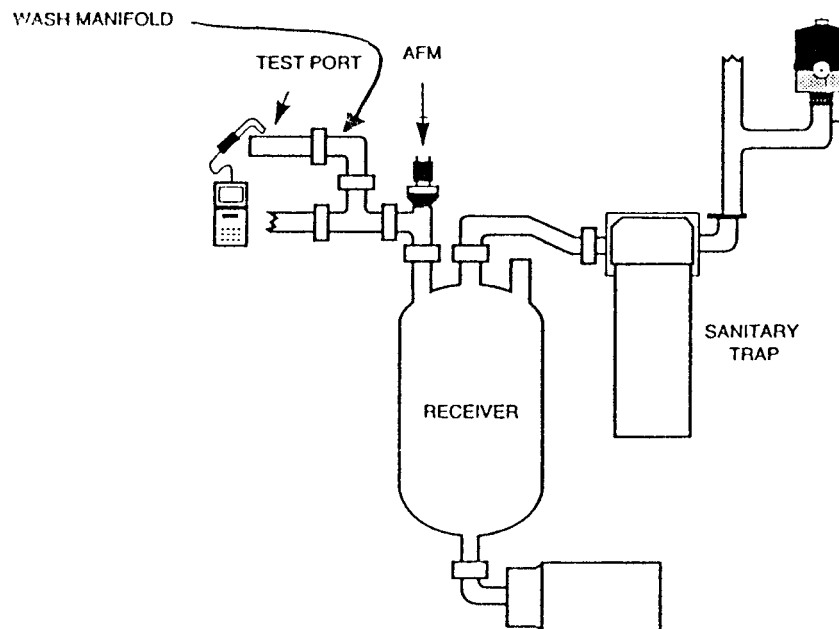

Figure 5 – Connection of air flowmeter

**8.1.1** Turn off the vacuum pump(s). Disconnect the vacuum regulator and plug the connection. Stop or isolate the pulsators, the milking units, and all vacuum-operated equipment.

**8.1.2** Connect an air flowmeter to a suitable T-piece near the vacuum pump as shown in figure 1 (or into the regulator connection point if there is no T-piece near the *vacuum pump*). Connect the test vacuum gauge to the test port near the pump inlet. Open the air flowmeter, and start the vacuum pump.

**8.1.3** Adjust the air flowmeter until the vacuum level matches the measurement in 6.2.1, and record the air flowmeter reading.

**8.1.4** Isolate the milk system by plugging the receiver airline (or trap line).

**8.1.5** Readjust the air flowmeter until the vacuum level matches the measurement in 8.1.3, and record the air flowmeter reading.

**8.1.6** Calculate and record *air leakage into the milk system* as the difference between the air flows measured in 8.1.5 and 8.1.3.

## **8.2 Vacuum pump capacity (see ASAE S518, 6.1)**

**8.2.1** Turn off the vacuum pump(s). Attach an air flowmeter as shown in figure 1, and connect the test vacuum gauge at or near the vacuum pump inlet. Isolate the vacuum pump and air flowmeter from the rest of the milking system.

**8.2.2** Open the air flowmeter, and restart the vacuum pump(s).

**8.2.3** Adjust the air flowmeter until the pump working vacuum matches the measurement made in 6.2.1.

**8.2.4** Record the air flowmeter reading as the *vacuum pump capacity*.

## **8.3 Vacuum pump speed (see ASAE S518, 6.6)**

With the milking machine operating according to 5.3 (or 8.2.3), measure and record the *vacuum pump speed* as its frequency of rotation ( $\text{min}^{-1}$ ).

## **9 Air flow tests for individual milking units**

### **9.1 Air leakage through vacuum shut-off valve (see ASAE S518, 19.2)**

**9.1.1** Connect a variable area air flowmeter between the long milk tube of an individual cluster and the milkline or weigh jar. The vacuum shall be set at the level recorded in 6.3.1 and the shut-off valve closed.

**9.1.2** Correct the flowmeter reading for vacuum level (see 4.4.2), and record the corrected air flow as the *shut-off valve leakage* for the individual cluster.

## **10 Pulsation tests (see ASAE S518, clause 13)**

**10.1** Disconnect the short pulse tube from the pulsation chamber nipple on one teatcup (for systems with simultaneous pulsation) or two teatcups per milking unit (for systems with alternating pulsation). Drain any liquid from the pulsation chambers, and attach a suitable T-piece between the nipple and short pulse tube. Connect the T-piece to a vacuum recorder.

**10.2** Record at least five pulsation cycles, and repeat the measurement for each unit.

**10.3** Analyze according to the definitions given in ASAE S300 to obtain the pulsation rate, pulsator ratio, and the b- and d-phases for each unit.

## **11 Tests of vacuum stability during milking**

Tests shall be conducted during a normal milking while the system is under full milk and air flow conditions.

### **11.1 Receiver vacuum stability (see ASAE S518, 6.2)**

**11.1.1** Connect a suitable vacuum recorder as near as practicable to the receiver, making sure that the connection is not in the milk stream. If necessary, the connection could be made in or through the sanitary trap.

**11.1.2** Record the vacuum changes in or near the receiver for 2 to 3 cycles (turns) in a parlor, or for 15 to 20 min in a stanchion barn, while milking units are being attached, while the units are on the cows, and as units are detached.

**11.1.3** Examine the recordings for any transient vacuum drop greater than 2 kPa (0.6 in. Hg).

### **11.2 Milkline vacuum stability (see ASAE S518, 14.1)**

**11.2.1** In stanchion barns, connect the vacuum recorder to a convenient, spare milk valve near the receiver end of the milkline, but at least 3 m (10 ft) from the receiver.

**11.2.2** In parlors, slide the milk hose back 12 to 24 mm (0.5 to 1 in.) from a convenient milkline inlet at least 3 m (10 ft) from the receiver, and insert a 12- or 14-gauge hypodermic needle through the milk hose and milk inlet. The needle should be at least 64 mm (2.5 in.) long to ensure proper location of the needle in the milkline. Ensure that the open beveled end of the needle is positioned within the top of the milkline, facing toward the receiver and, as much as possible, out of the milk stream from the milking unit to which it is attached. When these readings are completed, remove the needle and push the milk hose over the milk nipple so that the puncture hole made by the needle is covered by the inlet nipple.

**11.2.3** Record the vacuum changes in the milkline for 2 to 3 cycles (turns) in a parlor, or for 15 to 20 min in a stanchion barn, while milking units are being attached, while the units are on the cows, and as units are detached.

**11.2.4** Examine the recordings for any transient vacuum drop more than 2 kPa (0.6 in. Hg) below the corresponding vacuum level measured in the receiver in 11.1.3.

## **12 Evaluation of results**

**12.1** The measurements should be compared with those published by the manufacturer in their manuals and those specified in ASAE S518 to evaluate the milking machines performance.

**12.2** The operating characteristics for milking machines vary as a result of different manufacturers' designs. Therefore these characteristics shall be taken into consideration when the results are evaluated.

**12.3** Records of tests performed should indicate values for each measurement and the instrument used for each test performed.

NOTE – The report form developed and published in 1996 by the National Mastitis Council is suitable for recording the results of most of the tests described in this Engineering Practice.

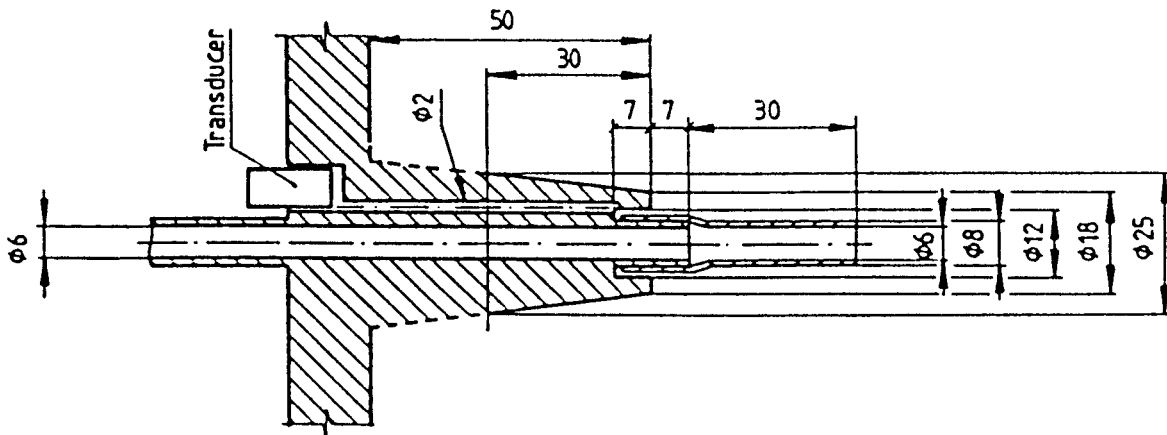

Figure A1 – Artificial teat. Dimensions are given in mm

**Annex A**  
(informative)

**Laboratory tests of vacuum drop in the milking unit**

**A1 Measuring equipment**

A1.1 A vacuum recording system as specified in 4.2.1.

A1.2 An artificial udder with teats according to figure A1 made of rigid material with a flexible tube at the teat end in a material that will collapse by the pressure of a closed liner.

A1.3 A water flowmeter with a minimum accuracy as specified in annex A4, and an air flowmeter with a minimum accuracy as specified in annex A5.

**A2 Measuring method**

Mean vacuum level shall be recorded at the teat-end (via the transducer shown in figure A1), or in the claw bowl or at the claw outlet, while water is drawn through artificial teats (figure A1). The milking unit shall work normally. Pulsation data shall be recorded and specified.

**A3 Description of the connection to the plant**

The connection to the plant shall be described by:

- length and internal diameter of the milk hose,
- the shape of the milk hose (see figure A2) by:
  - lifting height from the claw to the milking line (a),
  - lifting height from the teat base to the milking line (b),
  - vertical distance from claw to the highest point of the long milk tube (c),
  - vertical distance from the claw to the lowest point of the long milk tube (d),
  - horizontal distance from the claw to the milking line (e),
- description of the milk cock or milk inlet,
- description of the vacuum tap.

When units are being compared, the milk hose length shall be so matched that the distances b and e (see figure A2) will be the same for

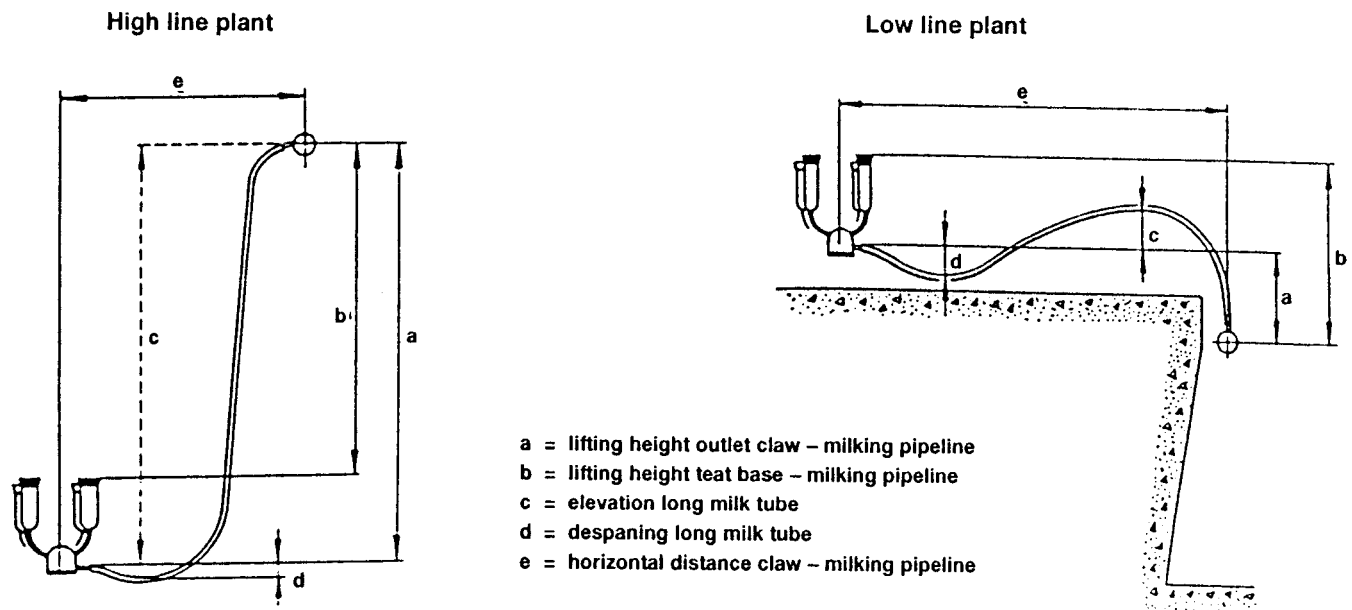

Figure A2 – Measurements for the installation of milking unit, with representative shape of the long milk tube

all units. So that measuring results can be compared, the dimension b should preferably be 1300 mm (52 in.) for highline, and 700 mm (28 in.) for lowline systems.

#### A4 Water flow rate

The water flow rate shall be specified and measured with an error of less than  $\pm 0.25$  L/min. The water temperature shall be 15 to 22 °C (59 to 72 °F). The reference water flow rate shall be  $5.0 \pm 0.25$  L/min. If other flow rates are used they should be chosen from the following: 0.5, 1, 3, 6, 9, or 12 L/min.

#### A5 Air flow rate

The air flow through the air vent shall be measured. The designated air admission rate through the test cluster shall be  $8.0 \pm 0.5$  L/min. If other flow rates are used they should be chosen from the following: 4, 12, 15, or 20 L/min.

#### A6 Measurement of the vacuum drop from components in the milk hose

The effect of components in the long milk tube shall be calculated by measuring the mean vacuum in a specified milking unit both with and without the component connected and by comparing the results.

**A6.1** Install the milking unit without components in the milk hose and record the measurements specified in A3.

**A6.2** Record the mean vacuum with a water flow rate of 5 L/min, split equally between all teatcups of a cluster.

**A6.3** Install the test component in the milk hose as specified by the manufacturer. Tubes normally used with the tested component shall be used. Adjust the length of the milk hose so that the dimensions measured according to A6.1 are replicated for the test given in A6.4.

**A6.4** Record the mean vacuum with the same water flow rate as in A6.2.

**A6.5** The vacuum drop caused by the tested component is the difference in the mean vacuum levels recorded in A6.2 and A6.4.

---

## Annex B (informative)

### Guidelines for accurate measurement of vacuum level

Do not trust the vacuum gauge on top of the air flowmeter unless the vacuum sensing tube has been lengthened to extend through the air flowmeter and into the receiver.

Suitable points for measurement of vacuum level in “quiet air” (air flow with minimal turbulence) on the sanitary side of the sanitary trap are as

follows:

- top of receiver with special test lid that has a nipple to attach hose to the vacuum gauge.
- first milk inlet on the milking line in parlor.
- milk inlet/nipple on wash manifold in round-the-barn pipelines with the system set in wash mode.
- vacuum supply hose to first weigh jar.

---

## Annex C (informative)

### Guidelines for accurate measurement of air flow

#### C1 Air flowmeter connections

For accurate air flowmeter readings, the flowmeter should be placed at or near the receiver (for direct-to-pipeline systems) or on the vacuum supply for weigh jar systems. Follow the air flowmeter manufacturer's recommendations when making measurements. It is important that the connection not restrict air port size to a size smaller than the throat of the flowmeter. In all cases, use the largest possible test port or flowmeter adapter size. Avoid restrictions. Following are some guidelines for minimum opening size:

Less than 2850 L/min (100 ft <sup>3</sup> /min)	= 30 mm (1.2 in.) minimum opening
2850 to 5000 L/min (100 to 175 ft <sup>3</sup> /min)	= 50 mm (2.0 in.) minimum opening
More than 5000 L/min (175 ft <sup>3</sup> /min)	= 75 mm (3.0 in.) minimum opening

#### C2 Corrections to air flowmeter readings

Most air flowmeters are calibrated to be accurate within  $+ / - 5\%$  at 50 kPa (15 in. Hg). At lower vacuum levels, the mass flow rate of air through each metering hole is reduced. For example, the mass flowrate of 33 kPa (10 in. Hg) is about 10% lower than at 50 kPa (15 in. Hg). Manufacturers can provide calibration charts for their flowmeters.

Generally, the correction factors are small and can be ignored for measurements made between 44 and 50 kPa (13 and 15 in. Hg). At lower vacuum levels, and/or at high air flow rates, it is good practice to make the necessary corrections. As a practical guideline, correction should be made to meter readings if the error is likely to exceed  $+ / - 55$  to 85 L/min (2 to 3 ft<sup>3</sup>/min) at air flows up to about 1400 L/min (50 ft<sup>3</sup>/min), or  $+ / - 5\%$  at higher air flows.